

▶ MX44AVW

User Manual

Thank you for purchasing this product.

For optimum performance and safety, please read these instructions carefully before connecting, operating or adjusting this product. Please keep this manual for future reference.



Surge Protection Device Recommended

This product contains sensitive electrical components that may be damaged by electrical spikes, surges, electric shock, lightning strikes, etc. Use of surge protection systems is highly recommended in order to protect and extend the life of your equipment.



Eco Friendly Packaging

This product has been packaged with fully recyclable materials, including compostable bags. Please help us to help the environment.

Contents

Introduction	03
Front Panel Description	04
Rear Panel Description	04
Operation and Connections	05
Front Panel Buttons	05
Infrared (IR) Control	05
EDID Management	06
Connection Schematic	07
Web-GUI - Log In and Initialisation	08
Web-GUI - Control	09
Web-GUI - Video Wall Mode	11
Web-GUI - Example Video Wall Configuration	13
Web-GUI - Multiview Mode	15
Web-GUI - Input	17
Web-GUI - Output	19
Web-GUI - Settings	21
Web-GUI - Users	24
Web-GUI - Update Firmware	25
Specifications	26
Package Contents	26
Maintenance	26
RS-232 Configuration and Telnet Commands	27
Certifications	31

Introduction

The Blustream MX44AVW is an advanced 4K HDMI 2.0 multi-purpose high-speed video processing system. The MX44AVW can be configured for 3 different output modes:

- 4x4 seamless matrix switcher
- Advanced video wall solution
- Quad multi-view presentation system

The MX44AVW supports advanced video wall configurations, allowing individual overlap and rotation of panels; multiview with pre-defined and customisable layouts using PIP, POP, PBP, and up to 4 window layouts.

The MX44AVW features a web browser interface module for control and configuration of the matrix with additional third party control achievable via the front-panel push buttons, IR remote control, RS-232 interface and TCP/IP. The MX44AVW is designed to achieve artistic video wall configurations within retail and showcase style installations.

FEATURES:

- Advanced 4K HDMI 2.0 multi-purpose high-speed video processor supporting matrix, multi-view, and video wall function
- Advanced video wall configuration allowing individual overlap and rotation of panels
- Multi-view mode supports PIP, PBP, POP, Dual, Triple and Quad-windows layouts with pre-defined and customisable configurations
- Seamless video switching
- Supports HDMI 2.0 4K UHD 60Hz 4:4:4 18Gbps specification including HDR
- Supports all industry standard video resolutions including VGA-WUXGA and 480i-4K
- Supports all known HDMI audio formats including Dolby Atmos, Dolby TrueHD, Dolby Digital Plus and DTS-HD Master Audio transmission
- HDMI audio breakout to analogue L/R audio and optical digital outputs concurrently
- IR routing
- Control via front panel, IR, RS-232, TCP/IP and web-GUI
- Supplied with Blustream 5V IR receiver and remote control
- HDCP2.2 compliant with advanced EDID management

Please note: a 1080i image is only supported in Matrix and Multiview mode, but will not work on Video Wall mode.

Front Panel Description

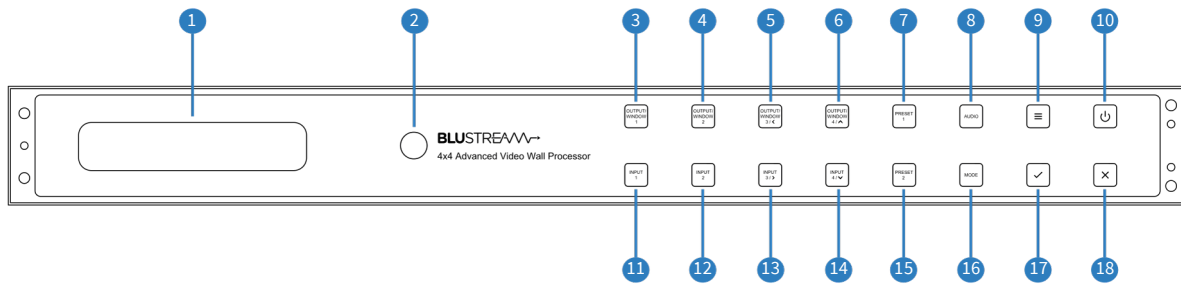

- 1 LCD Display
- 2 IR Receiver
- 3 Output/Window 1 Button
- 4 Output/Window 2 Button
- 5 Output/Window 3 / Left Button
- 6 Output/Window 4 / Up Button
- 7 Preset 1 Button
- 8 Audio Button
- 9 Menu Button
- 10 Power Button
- 11 Input 1 Button
- 12 Input 2 Button
- 13 Input 3 / Right Button
- 14 Input 4 / Down Button
- 15 Preset 2 Button
- 16 Mode Button
- 17 Select Button
- 18 Escape Button

Rear Panel Description

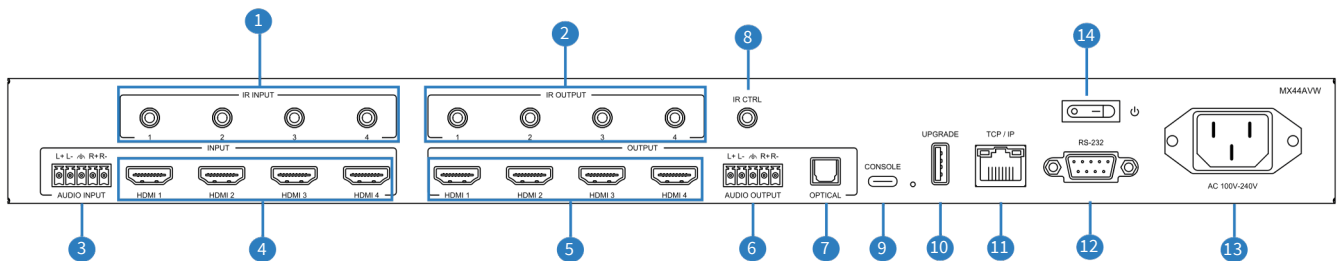

- 1 4 x 3.5mm stereo jack: IR Inputs
- 2 4 x 3.5mm mono jacks: IR Outputs
- 3 1 x 5-Pin Phoenix connector: 2ch Analogue Audio Input
- 4 4 x HDMI Type A, 19-pin, female: Video Inputs
- 5 4 x HDMI Type A, 19-pin female: Video Outputs
- 6 1 x 5-Pin Phoenix connector: 2ch Analogue Audio Output
- 7 1 x Optical (S/PDIF): 2ch Digital Audio Output
- 8 1 x 3.5mm stereo jack: IR Input
- 9 1 x USB Type C, female: Console Control Port
- 10 1 x USB Type A female: Firmware Upgrade Port
- 11 1 x 1 x RJ45, female: TCP/IP Control Port
- 12 1 x 1 x DB-9, female: RS-232 Control Port
- 13 1 x Mains C14 IEC Power Inlet
- 14 1 x Power Switch

Operation and Connections

The MX44AVW is configured and initially operated from the in-built Web-GUI. Connect your input and output devices, the TCP/IP port, and power to the rear of the unit.

Front Panel Buttons

The front panel of the MX44AVW features a menu system to provide quick configuration of key features.

Press the menu button to bring up the menu system of the matrix on the front panel display. While the menu system is active, the buttons with the Left, Right, Up and Down icons can be used to navigate through the options. Use Select button or escape button to change or modify settings.

To Factory Reset the MX44AVW: Press and hold the 'X' button for 5 seconds. A message will appear on the display "Do you really want to factory reset the matrix?". Press the 'Select' [tick] button to confirm, press the 'Escape' [X] button to cancel.

Infrared (IR) Control

The Blustream range of matrix products include Matrix control via IR.

IMPORTANT: Blustream Infrared products are all 5V and NOT compatible with alternative manufacturers Infrared solutions. When using third party 12V IR control solutions please use the Blustream IRCAB cable for IR conversion.

IR Receiver - IRR

Blustream 5V IR receiver to receive an IR signal for control of the matrix.

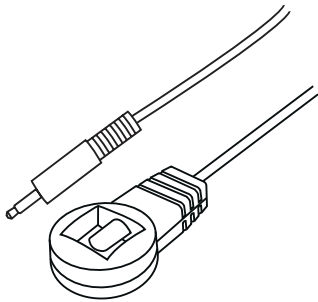

IR Receiver - Stereo 3.5mm

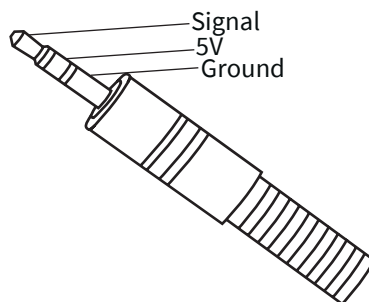

IR Control Cable - IRCAB

Blustream IR Control cable 3.5mm Mono to 3.5mm Stereo for linking third party control solutions to Blustream products.

Compatible with 12V IR 3rd party products.

Please Note: cable is directional as indicated

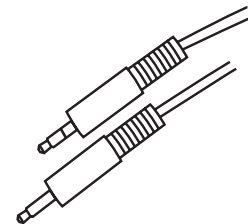

EDID Management

EDID (Extended Display Identification Data) is a data structure that is used between a display and a source. This data is used by the source to find out what audio and video resolutions are supported by the display. By pre-determining the video resolution and audio format of the source and display device/s you can reduce the time needed for EDID hand shaking thus making switching quicker, and more reliable.

Configuration of the EDID settings for each input can be achieved by using the Web-GUI or using the following commands to specify the required EDID.

Please see the section on RS-232 and Telnet API at the end of this manual for full connectivity information

EDID xx DF zz

xx=00:

xx=[01...04]:

zz=00: zz=01: zz=02: zz=03: zz=04: zz=05: zz=06: zz=07: zz=08: zz=09: zz=10: zz=11: zz=12: zz=13: zz=14: zz=15: zz=16:
zz=17: zz=30: zz=31: zz=32: zz=33: zz=34: zz=35: zz=36: zz=37: zz=38: zz=39:

Set Input:xx EDID To Default EDID:zz Select All Input Port Select One Input Port HDMI 1080p@60Hz, Audio 2ch PCM (default) HDMI 1080p@60Hz, Audio 5.1ch DTS/DOLBY HDMI 1080p@60Hz, Audio 7.1ch DTS/DOLBY/HD HDMI 1080i@60Hz, Audio 2ch PCM HDMI 1080i@60Hz, Audio 5.1ch DTS/DOLBY HDMI 1080i@60Hz, Audio 7.1ch DTS/DOLBY/HD HDMI 1080p@60Hz/3D, Audio 2ch PCM HDMI 1080p@60Hz/3D, Audio 5.1ch DTS/DOLBY HDMI 1080p@60Hz/3D, Audio 7.1ch DTS/DOLBY/HD HDMI 4K@30Hz 4:4:4, Audio 2ch PCM HDMI 4K@30Hz 4:4:4, Audio 5.1ch DTS/DOLBY HDMI 4K@30Hz 4:4:4, Audio 7.1ch DTS/DOLBY/HD HDMI 4K@60Hz 4:2:0/4K@30Hz 4:4:4, Audio 2ch PCM HDMI 4K@60Hz 4:2:0/4K@30Hz 4:4:4, Audio 5.1ch DTS/DOLBY HDMI 4K@60Hz 4:2:0/4K@30Hz 4:4:4, Audio 7.1ch DTS/DOLBY/HD HDMI 4K@60Hz 4:4:4, 8-bit, Audio 2ch PCM HDMI 4K@60Hz 4:4:4, 8-bit, Audio 5.1ch DTS/DOLBY HDMI 4K@60Hz 4:4:4, 8-bit, Audio 7.1ch DTS/DOLBY/HD DVI 1280x1024@60Hz, Audio None DVI 1920x1080@60Hz, Audio None DVI 1920x1200@60Hz, Audio None DVI 1920x1200@60Hz, Audio 5.1ch EDID Pass-through (Copy from Output 1) EDID Pass-through (Copy from Output 2) EDID Pass-through (Copy from Output 3) EDID Pass-through (Copy from Output 4) User EDID 1 User EDID 2

Connection Schematic

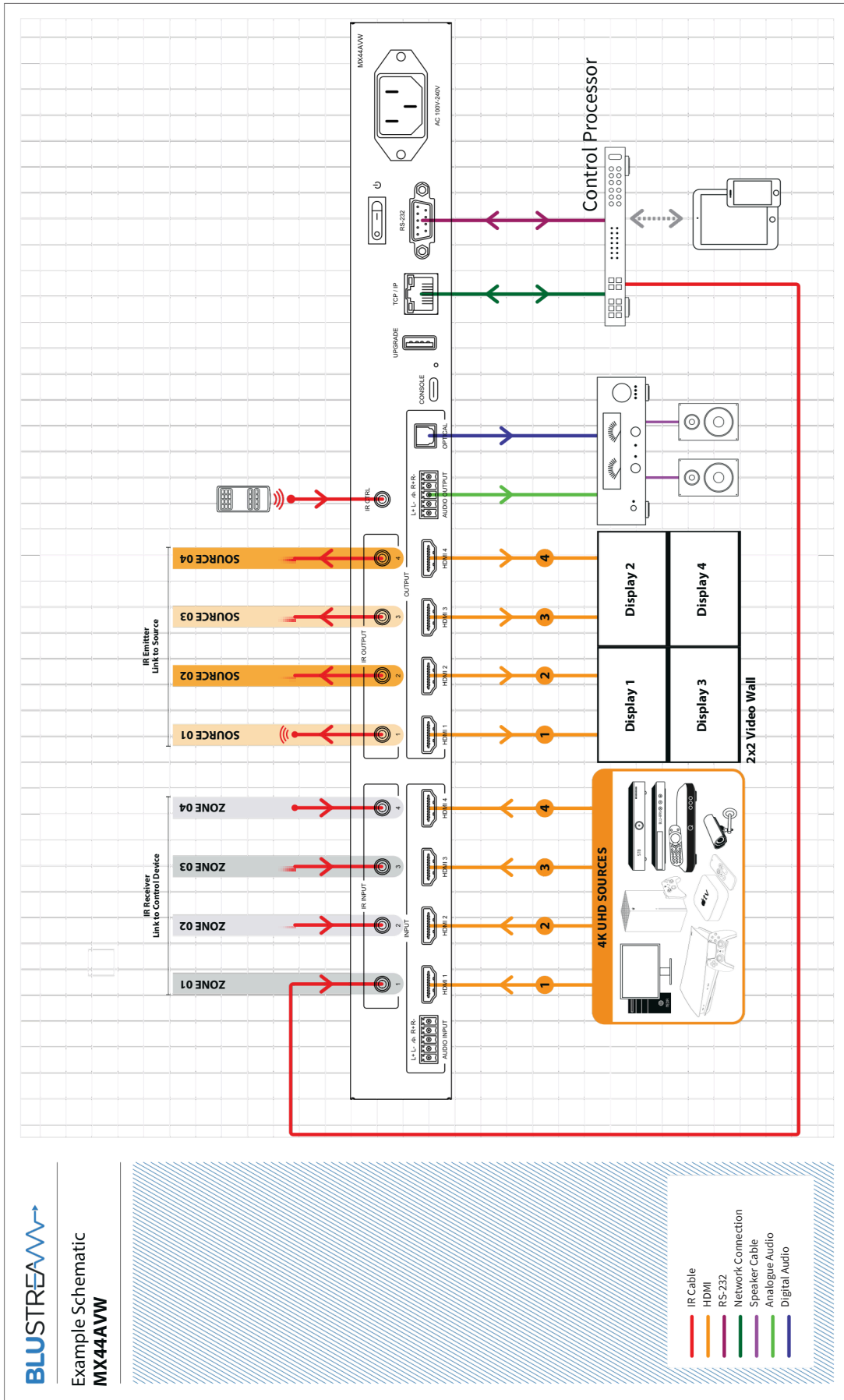

Web-GUI - Log In and Initialisation

The following sections will take you through the operation of the units web-GUI. You must connect the TCP/IP RJ45 socket to your local network, or directly from your computer to the MX44AVW, in order to access the product's web-GUI.

By default the unit is set to DHCP, however if a DHCP server (eg: network router) is not installed, the unit's IP address will revert to below details:

Default IP Address is: [192.168.0.200](#)

Default Admin Username is: [blustream](#)

Default Admin Password is: [@BlS1234](#)

Default Domain is: [mx44avw.local](#)

Login Page:

The web-GUI supports multiple users along with multiple user permissions as follows:

- Admin (Blustream) The Admin account allows full access to all functions and configuration of the unit
- Guest When enabled, the Guest can access the control page without a password
Enter the username: Guest, and press login

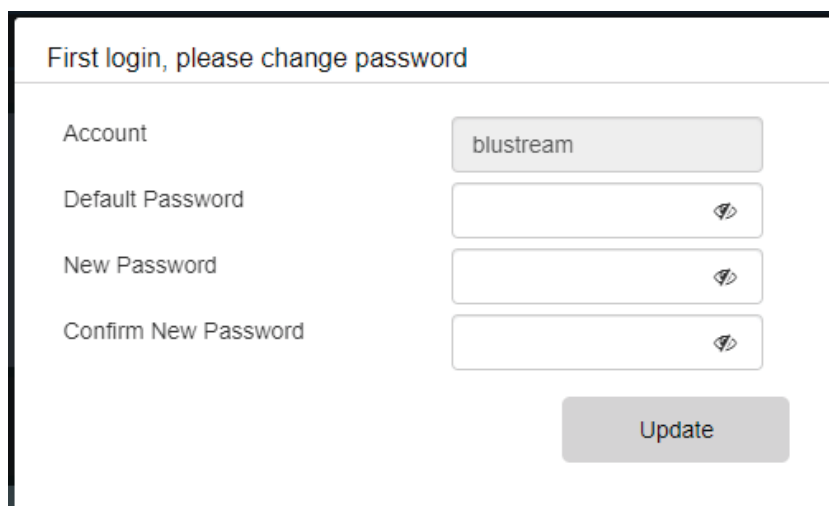

The screenshot shows a web form titled "First login, please change password". It contains four input fields: "Account" (pre-filled with "blustream"), "Default Password", "New Password", and "Confirm New Password". Each password field has a toggle icon for visibility. An "Update" button is located at the bottom right of the form.

Please note: the first time the Administrator logs into the web-GUI of the MX44AVW, the default password must be changed to a unique password. Please retain this password for future use. Forgetting the password will mean having to factory reset the unit, losing all configuration settings. The password needs to be a minimum of 8 characters, and contain a minimum of 1x lowercase letter, 1x uppercase letter, 1x number and 1x symbol.

Passwords can be changed as required within the web-GUI of the unit once logged in.

Web-GUI - Control

After logging into the MX44AVW, the user will be directed to the Control page.

From the control page, settings related to Matrix mode can be modified and configured.

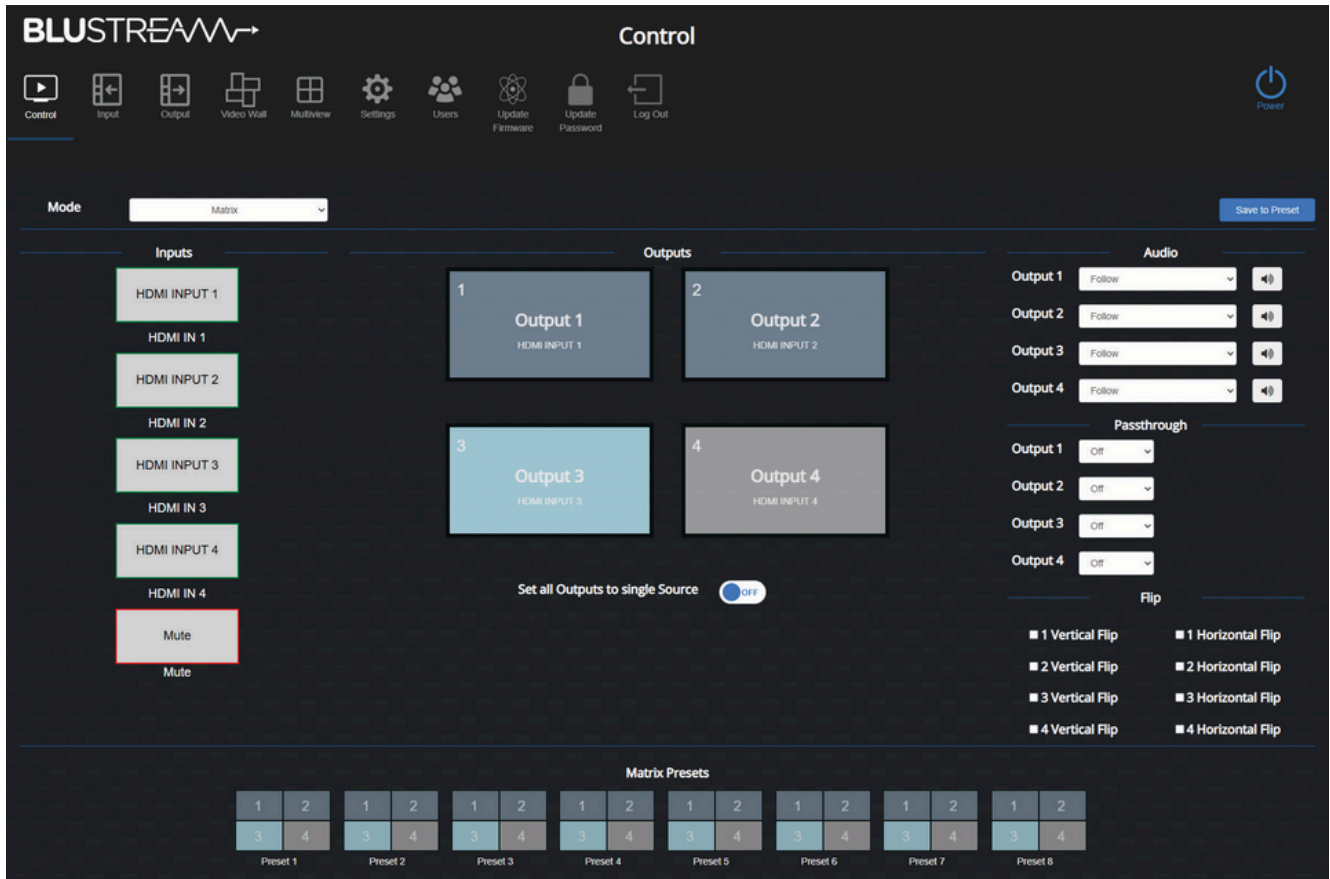

Mode:

The operating mode of the MX44AVW can be changed using the drop down menu.

Please note: Changing modes will redirect the web-GUI to the corresponding page. If the web-GUI is not on the page relating to the current operating mode, a warning will be displayed in the top right hand corner and that page's functionality will be disabled.

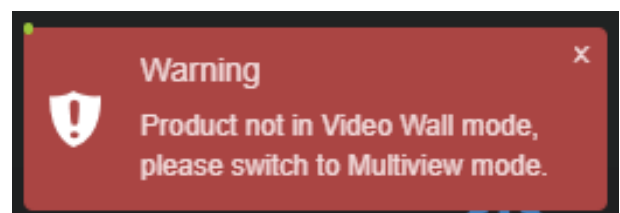

Matrix Mode:

Matrix mode allows the MX44AVW to operate as a video matrix. Sources can be assigned to any output, pass-through overrides can be applied, and audio can be routed through the matrix.

Input s:

- The 4 x HDMI inputs are listed here, as well as an option for video mute. Each input, including video mute, can be dragged and dropped on to the desired output. Each input is displayed with a name which can be set in the Input page
- When no source connected, the input will be highlighted in a red border
- When a source is connected, the input will be highlighted in a green border

Outputs:

- The 4 x HDMI output windows are labelled with their name, and with the name of the input currently assigned. Matrix control is achieved by dragging and dropping an input onto the desired output

Matrix Presets:

- The MX44AVW contains 8 custom presets that can be switched to by pressing the corresponding preset button. These can be used to easily recall settings and switch between multiple configurations
- Once configured, press the Save to Preset button to open a sub menu, and then select the desired preset number. The configuration will be saved to the selected preset number
- The preset icon will change depending on the matrix configuration, allowing for easy identification of presets

Set All Outputs to Single Source:

- By pressing this toggle, all outputs can be set to follow a single input source
- The desired input can be dragged and dropped anywhere on the output windows

Audio:

- Using the drop down menu, audio matrix control can be achieved by selecting the desired audio source for each output
- Selection can be made to embed audio from any of the HDMI input sources or external audio in
- The audio for each output can also be set to Follow, in which the audio of the HDMI input assigned by will played.

Pass-through:

- Pass-through can be applied for any of the HDMI outputs, in which the input assigned will ignore the scaler mode set in the Outputs page

Flip:

- Each of the 4 outputs can be flipped horizontally and/or vertically by toggling the respective check box

Please note: Seamless switching can only be achieved with the scaler set to 'Pass-through' (disabled).

Web-GUI - Video Wall Mode

Video Wall mode allows the outputs of the MX44AVW to operate as a video wall. The video wall allows an input to be displayed across any configuration of the 4 video wall windows: they can be tiled together contiguously or overlapped in a custom formation in order to form one large screen to display an input. The video wall render, represents the entire input screen. Each video wall window will output the section of the input that it is covering. For example, if the video wall window are setup in a 2 x 2 configuration, each window will display a quarter of the input.

Please note: If the video wall inputs are positioned in such a way that the black background of the input render is showing, there will be part of the input that will not be displayed across any of the video wall outputs.

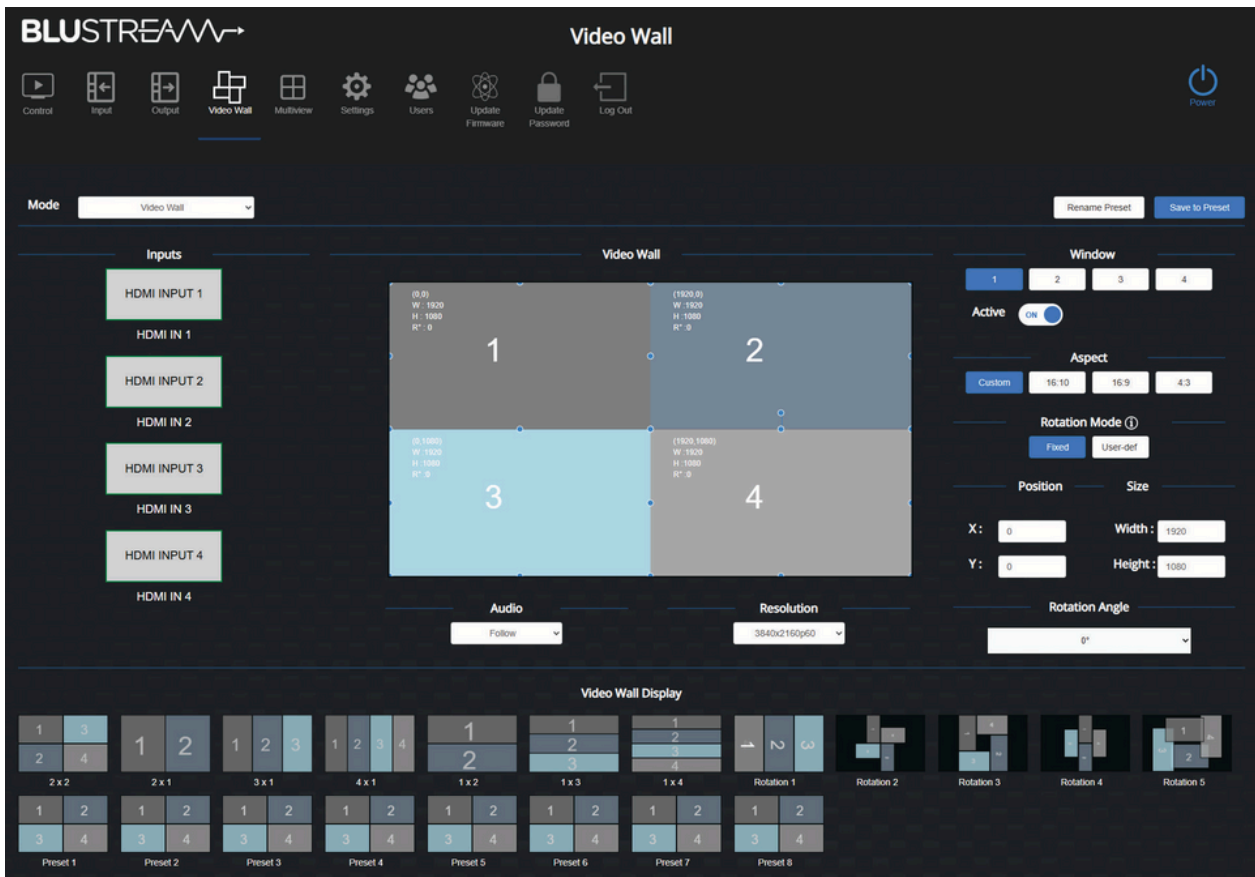

Input s:

- The Inputs section lists the 4 x HDMI inputs. Each input is displayed with a name which can be set in the Input page.
- When no source is connected, the input will be highlighted with a red border
- When a source is connected, the input will be highlighted with a green border
- To set the input for the video wall, press the desired input. It will automatically switch while retaining the video wall setup

Video Wall Configuration:

The unit allows for configuration of the position, rotation, scale and source of each video wall window. The windows can be moved around by pressing and dragging the window to the desired position. The scale and rotation can be modified by using the sizing handles:

- The sizing handles on the top and bottom of the window will scale the window in the y-axis (horizontally)
- The sizing handles on the left and right of the window will scale the window in the x-axis (vertically)
- The sizing handles on the corners will scale the window with regards to aspect ratio
- The rotation handle will rotate the window while in User-defined Angle Rotation mode. If in Fixed Angle Rotation mode, a warning dialog will be displayed

Please note: The rotation handle will only be active when the window is in User-defined Angle rotation

mode.

Web-GUI - Video Wall Mode (continued)

Window:

- Select the video wall window to modify. Any changes in the following sections will be applied to selected window
- The window can also be disabled using the 'Active' toggle

Aspect (setting applied to selected Video Wall window):

Amends the aspect ratio of the selected window.

- Custom allows the aspect ratio to be manipulated manually, stretching or compressing the window to the ratio set
- 16:10 / 16:9 / 4:3 fixes the aspect to one of the 3 most common aspect ratios used across most media devices

Please note: If a predefined aspect ratio is selected, and the width and height are manually adjusted, when using any of the sizing handles, the window will snap back to the selected aspect ratio and lose the custom ratio.

Rotation Mode & Rotation Angle (setting applied to selected Video Wall window):

Each window can operate in one of two modes for rotation:

- In Fixed Angle Rotation, the window can be rotated at 90(degree) intervals. The angle (0, 90, 180, 270) can be set from the Rotation Angle drop down menu. The rotation handle in the Video Wall render will be disabled
- In User-defined Angle Rotation, the video wall window can be rotated to any angle (0-360). The angle can be set in Rotation Angle input field, or by using the rotation handle for the selected window in the video wall render

Please note: If any of the video wall windows are in User-defined Angle Rotation mode, the maximum resolution of the Video Wall output will be limited to 1920x1080p

Position & Size (setting applied to selected Video Wall window):

- To set the position of the selected window, enter the desired location in the X & Y fields. The position coordinates refer to the top left corner of each window. (0,0) begins at the top left corner of the output render
- To set the size of the selected window, enter the width and height in pixels into the respective fields. When a fixed aspect ratio is selected for the window, the window will be forced to re-size to maintain the selected aspect ratio

Presets:

- The MX44AVW contains 12 pre-loaded presets that can be switched to by pressing the corresponding preset button
- An additional 8 custom presets can be saved to easily recall settings and switch between multiple configurations. Once configured, press the 'Save to Preset' button to open a sub menu, and then select the desired preset number. The configuration will be saved to the selected preset number
- The preset icon will change depending on the matrix configuration, allowing for easy identification of presets

Audio:

- All four HDMI outputs can be set to play audio from the same source device. It does not have to match the video wall input source
- It can also be set to follow or to play external audio through the phoenix connector port
- Select the desired audio input from the drop down menu to embed into the output

Resolution:

- Controls the resolution for the output window
- Select the desired resolution from the drop down menu

Please note: The output may display black bars depending on the output signal (i.e: Aspect Ratio)

Web-GUI - Example Video Wall Configuration

The Video Wall presets can be used to quickly set a base configuration to work from: it is very easy to manipulate the video wall to suit the needs on your installation. As an example, the following pages will show how to create a 3 x 1 a video wall from scratch:



With the default 2 x 2 Video Wall loaded, select one of the windows, and turn off its active toggle.

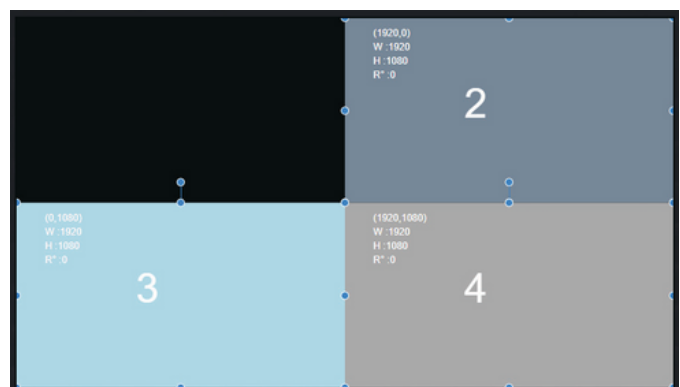

Next, select the window that correspond to the first screen. Click and drag the window to the corresponding position of the video wall.

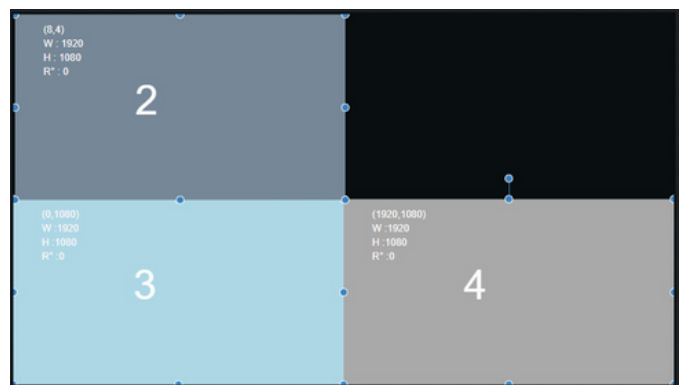

Next, modify the size of the window by clicking and dragging on one of the sizing handles in the corner. Resize the window to match the corresponding screen on the video wall.

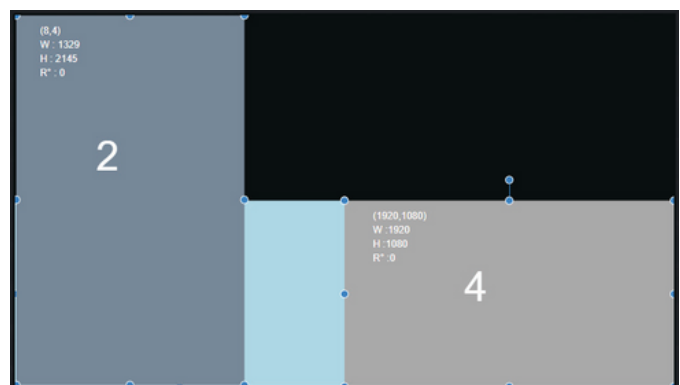

Web-GUI - Example Video Wall Configuration (continued)

Repeat the above for the remaining two windows.

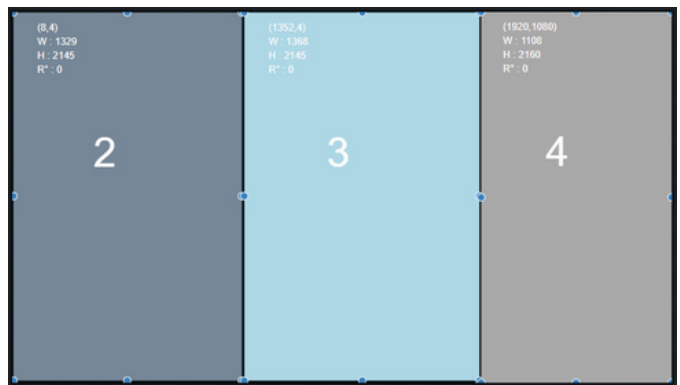
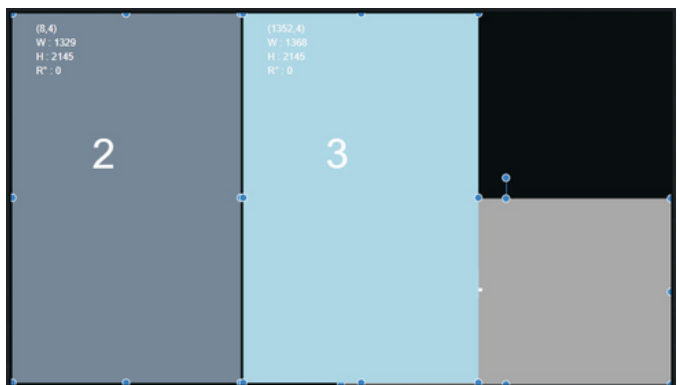
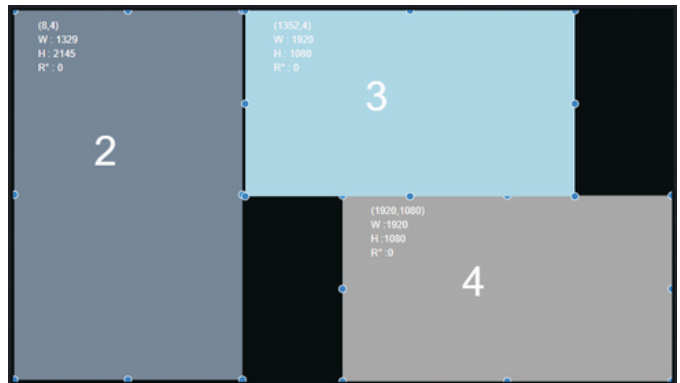

Once the screens are in relative position, you can now fine tune the position and size using with the manual input boxes.

Finally, the input for the video wall can be set by pressing one of the 4 x HDMI Inputs. The input will be applied across the video wall configuration.

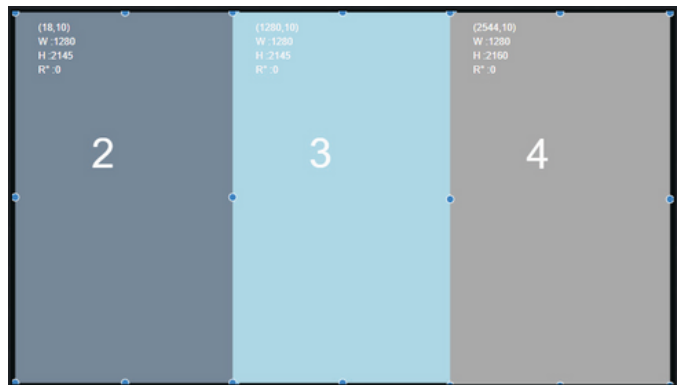

Web-GUI - Multiview Mode

Multiview mode allows the outputs of the MX44AVW to operate in up to 2 x multiview configurations: up to 4 x windows can be displayed at once in either configuration and settings for size & position can be configured independently for each multiview configuration.

Each window displayed represents a source input in a multiview configuration.

The windows are labelled 1-4 and display information such as the position of the window, the height and width of the window, and the source currently connected.

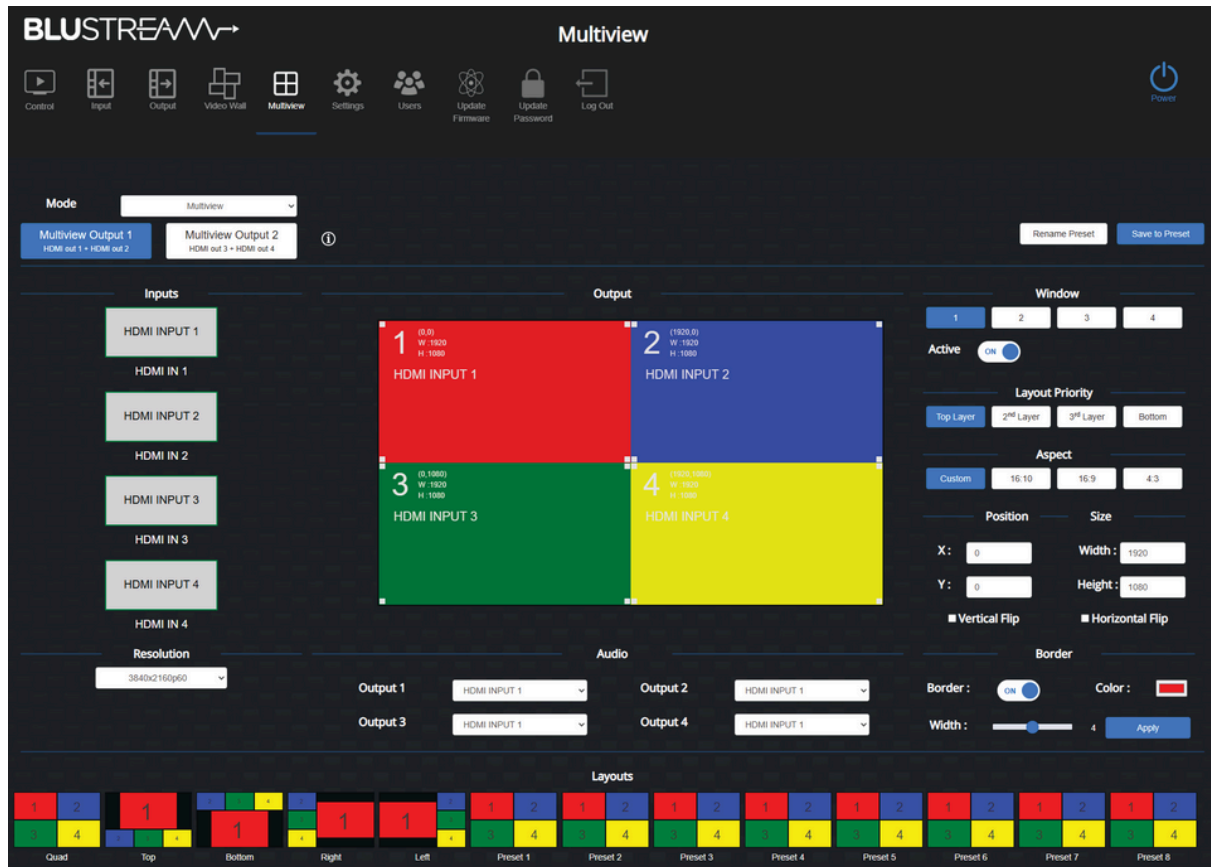

Multiview Output 1, & Multiview Output 2:

Up to two independent multiview configurations can be displayed at any time:

- Multiview Output 1 will be simultaneously displayed on HDMI outputs 1 & 2
- Multiview Output 2 will be simultaneously displayed on HDMI outputs 3 & 4

Each configuration can be adjusted by selecting their respective button

Resolution:

- Set the resolution for the Multiview output. This will apply to both simultaneous outputs
- Select the desired resolution from the drop down menu

Inputs:

- The 4 x HDMI inputs are listed here. Each input can be dragged and dropped on to the desired output. Each input is displayed with a name which can be set in the Input page
- When no source is connected, the input will be highlighted with a red border
- When a source is connected, the input will be highlighted with a green border

Web-GUI - Multiview Mode (continued)

Output:

- The output windows displays a render of the location and size of each window in the Multiview configuration
- The windows can be moved around by pressing and dragging the window to the desired position. The scale can be modified by using the sizing handles at the corner of each window
- When a fixed aspect ratio is selected for the window, the window will be forced re-sized to maintain the selected aspect ratio

Window:

Select the multiview window to modify. Any changes in the following sections will be applied to the selected window. The window can also be disabled using the 'Active' toggle

Layout Priority (setting applied to selected Multiview window):

- Sets the layer the window is on, affecting which windows render above or below the specified window

Aspect (setting applied to selected Multiview window):

Amends the aspect ratio of the selected window.

- Custom allows the aspect ratio to be manipulated manually, stretching or compressing the window to the ratio set
- 16:10 / 16:9 / 4:3 fixes the aspect to one of the 3 most common aspect ratios used across most media devices

Position & Size (setting applied to selected Multiview window):

- To set the position of the selected window, enter the desired location in the X & Y fields. The position coordinates refer to the top left corner of each window. (0,0) begins at the top left corner of the output render
- To set the size of the selected window, enter the width and height in pixels into the respective fields. When a fixed aspect ratio is selected for the window, the window will be forced re-sized to maintain the selected aspect ratio
- To flip the selected window horizontally and/or vertically, press the corresponding check box.

Border (setting applied to the selected Multiview window):

Enables a border around the window that is visible on the HDMI output

- It's colour and width can be set using the respective field
- Press Apply to save the changes

Layouts:

- The MX44AVW contains 5 pre-loaded presets that can be switched to by pressing the corresponding preset button
- An additional 8 custom presets can be saved to easily recall settings and switch between multiple configurations. Once configured, press the Save to Preset button to open a sub menu, and then select the desired preset number. The configuration will be saved to the selected preset number. The preset icon will change depending on the matrix configuration, allowing for easy identification of presets

Audio:

- All four HDMI outputs can be set to play audio from any of the HDMI inputs. It can also be set to play external audio through the phoenix connector port
- Select the desired audio input corresponding to the desired output to route audio through the matrix

Web-GUI - Input

The Input configuration page allows renaming and EDID selection for each input connected to the MX44AVW.

Clicking the 'Update' button to the right of each input allows for the name of the source to be entered. This name is updated across the web-GUI globally for simpler selection of inputs

Name:

- Displays the name of the input

HDMI Cable:

- Displays the connection status of the input port

Signal:

- The MX44AVW can detect the input signal and display information such as the resolution, colour depth, colour space, and HDCP version

EDID:

- EDID selection can be made for each input source device to ensure the correct video and audio resolutions are requested from the MX44AVW to the source. The drop down menu contains all of the EDID formats supported, the ability to copy the EDID from another output with a connected display, and also the ability to load up to 10 x user defined EDIDs

Actions:

- The Update button will open a sub menu to configure the following options:

Name:

- The name of the input can be updated by entering a new name into the name field pressing the Update button

Web-GUI - Input (continued)

User Defined EDID

- It is possible to upload custom EDID .bin files to the MX44AVW if a specific EDID is not listed within the standard formats. A custom EDID file can be generated from a third party EDID generation tool, and uploaded using the Load and Upload buttons. There are 10 x custom EDID slots available that can be directed at any of the 4 x inputs.

Once a file has been uploaded, it's name will be displayed under EDID File Name when the corresponding User Defined EDID is selected from the drop down menu

Analogue Audio Input Level

- The analogue audio input level can be adjusted from here, slide the Left and/or Right volume slider to set the desired volume level.

Web-GUI - Output

The Output configuration page allows renaming and EDID selection for each output sink connected to the MX44AVW. Clicking the 'Update' button to the right of each output allows for the renaming. This name is updated globally across the web-GUI for simpler selection of inputs:

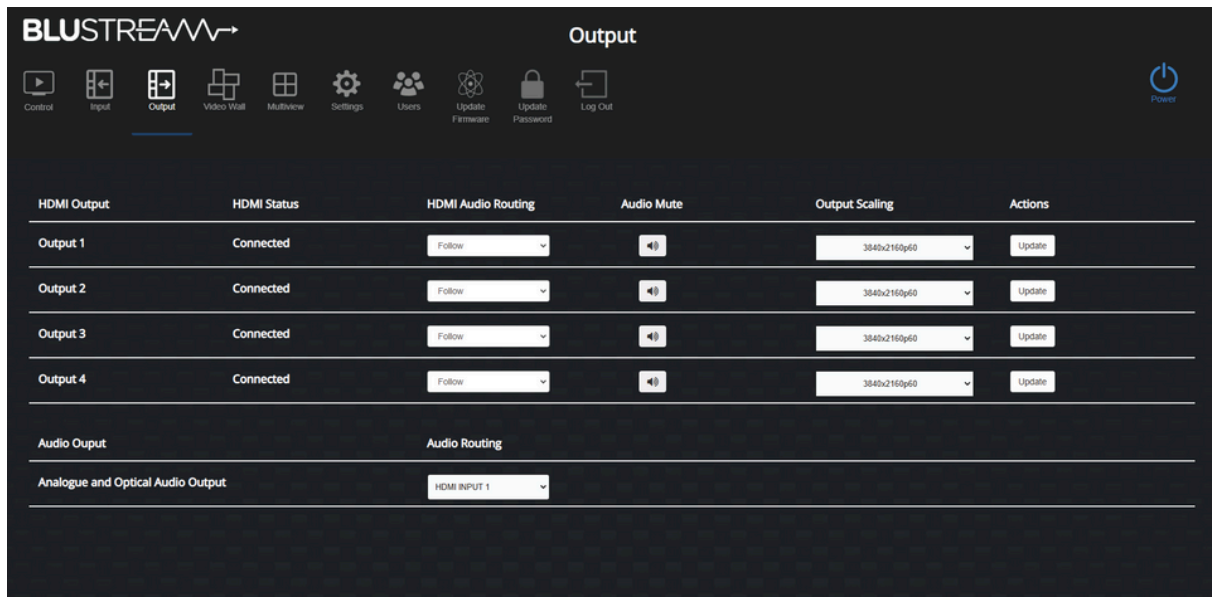

HDMI Output:

- Lists the name of the output

HDMI Status:

- Displays the connection status of the output port

HDMI Audio Routing:

- Allows selection of audio source embedding from another HDMI source or from an external source via the audio in port
- Select an input source from the drop down menu, or select Follow for the output to play the audio of the connected HDMI input

Audio Mute:

- Mutes the audio of the output
- Press the toggle to mute / unmute

Output Scaling:

- Allows the resolution for each output to be individually controlled
- If in Video Wall or Multiview mode, the output scaling will be disabled and can be set in their respective pages

The Update button will open a sub menu to configure the following items:

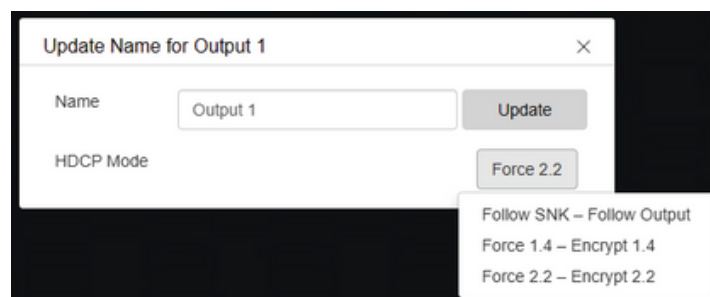

Web-GUI - Output (continued)

Name:

- The name of the output can be updated by entering a new name into the name field pressing the Update button

HDCP Mode:

- The MX44AVW can set the HDCP mode of each output independently. The currently selected mode is displayed on a button as:

Force 2.2, Force 1.4, Follow SNK (sink / display compliance)

To change the HDCP mode of the selected output, press the button with the current mode to open a drop down menu, and select the desired HDCP mode. The button will update to display the currently selected mode.

Audio Output:

- Allows selection of an audio input source to be routed to the analogue and optical outputs on the back of unit

Audio Routing:

- Select an input source from the drop down menu; select Follow for the output to play the audio of the connected HDMI input

Please note: The analogue and optical outputs are tied together and cannot be set to output different signals.

Web-GUI - Settings

The Settings page allows for configuration of various functions of the MX44AVW, and provides information such as firmware version, network details, and temperature.

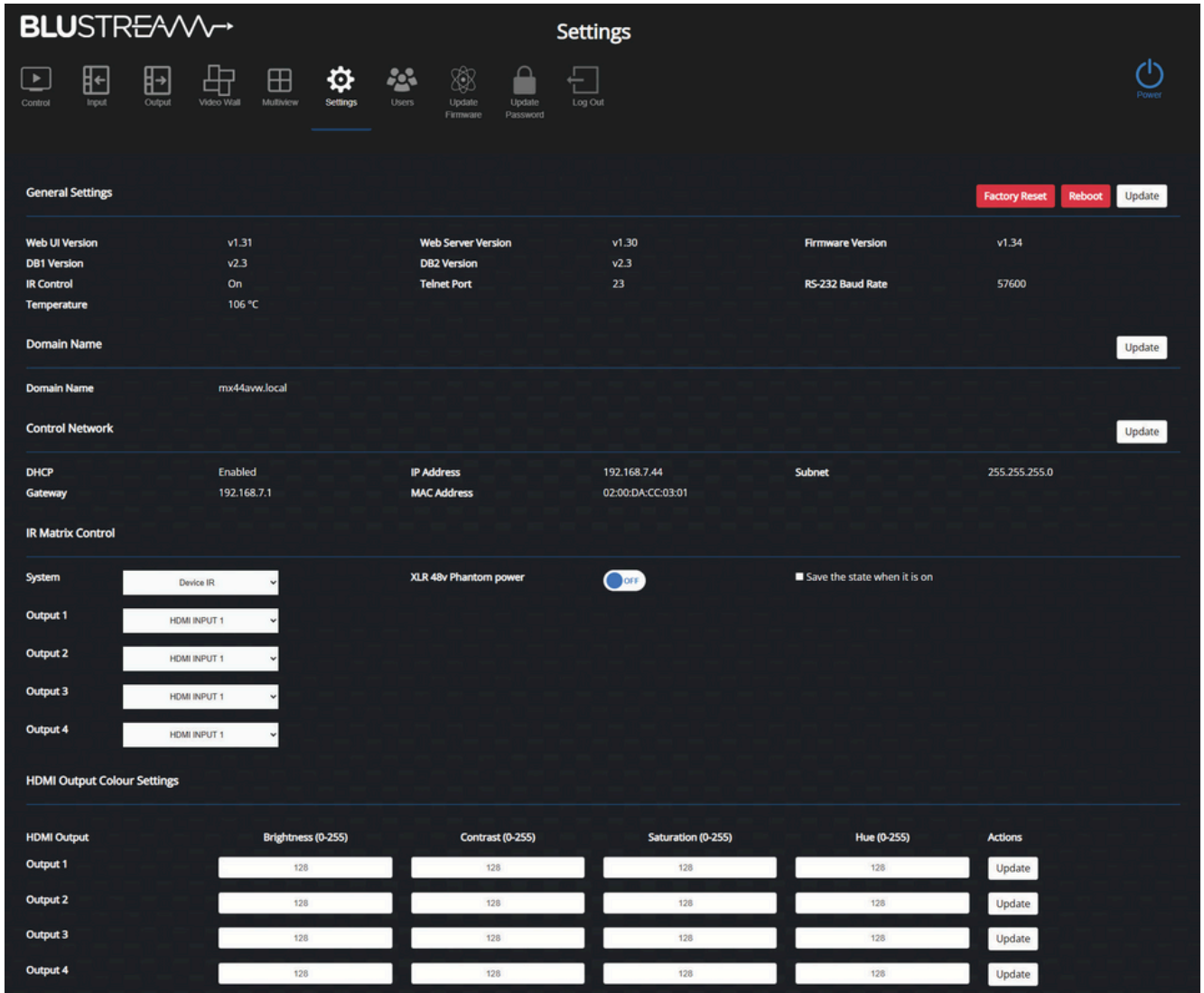

General Settings:

The Update button will open a sub menu to configure the following options:

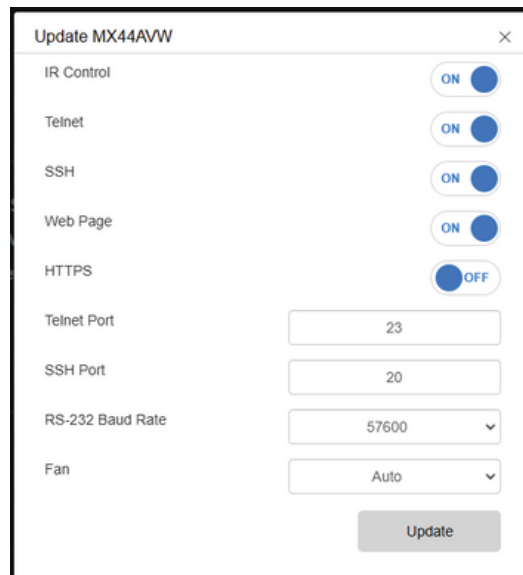

General Settings (continued)

- IR Control ON / OFF
- Telnet ON / OFF
- SSH ON / OFF
- Web Page ON / OFF

WARNING: Setting the Web Page to OFF will disable the web-GUI; it can only be re-enabled by using the API

- HTTPS ON / OFF
- Telnet Port Default: 23
- SSH Port Default : 20
- RS-232 Baud Rate 9600 / 19200 / 38400 / 57600 / 115200
- Fan Auto / Always On / Always Off

WARNING: Setting the fan to 'Always Off' is not recommended

Press the Update button at the bottom of the sub menu to apply changes.

Domain Name:

Where the IP address of the MX44AVW is not known, the Domain Name can be used to connect to the web-GUI. By default this is set to mx44avw.local

The Update button will open a sub menu to configure the following option:



- Domain Name Alphanumeric characters, no spaces

Press the Update button at the bottom of the sub menu to apply any changes; the updated domain name will be displayed.

Control Network:

Network settings for the connected TCP/IP port can be configured from this sections. The Update button will open a sub menu to configure the following items:

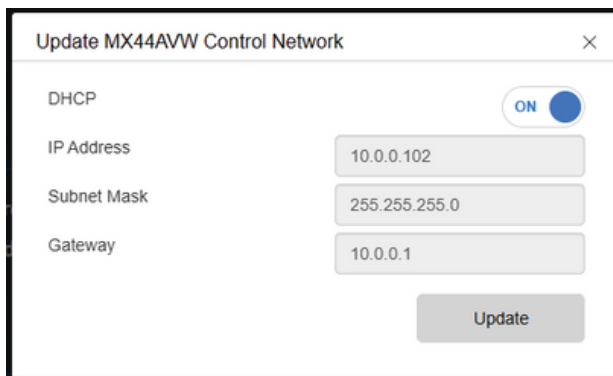

- DHCP ON / OFF
- IP Address Manually assign the IP Address of the MX44AVW, disabled if DHCP is on
- Subnet Mask Manually set the Subnet Mask, disabled if DHCP is on
- Gateway Manually set the Gateway, disabled if DHCP is on

Web-GUI - Users

The Users page allows for configuration of the Guest user’s privileges. Permissions for individual features can be enabled and disabled.

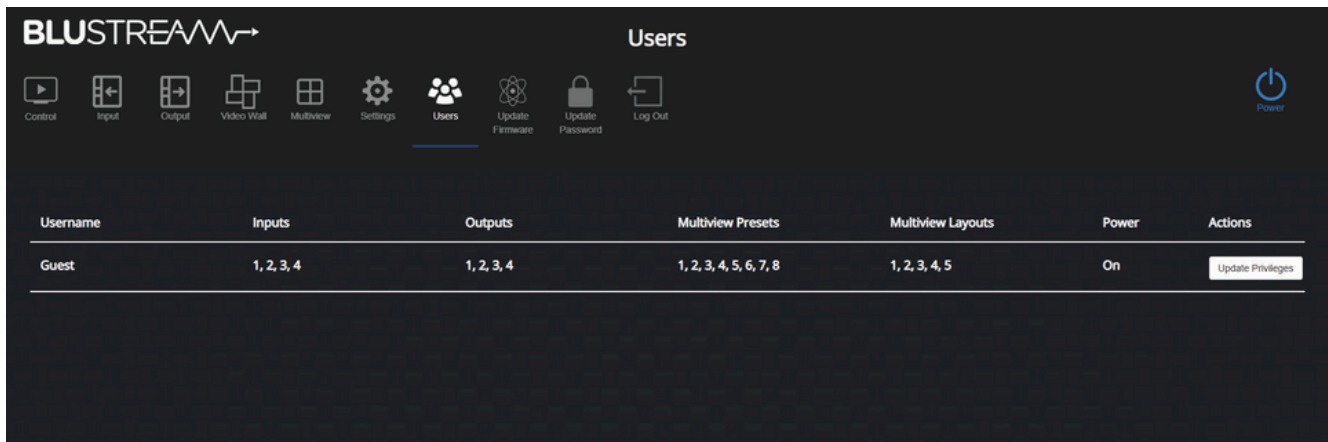

The Update Privileges button will open a sub menu to configure the following options:



Once the privileges have been configured, press the Update button at the bottom of the sub menu to apply any changes. The Guest user will now allow be able to access the functions that have been enabled.

Web-GUI - Update Firmware

The Update Firmware page allows for the MX44AVW's firmware to be updated. The latest firmware can be found on the product's download page on the Blustream website.

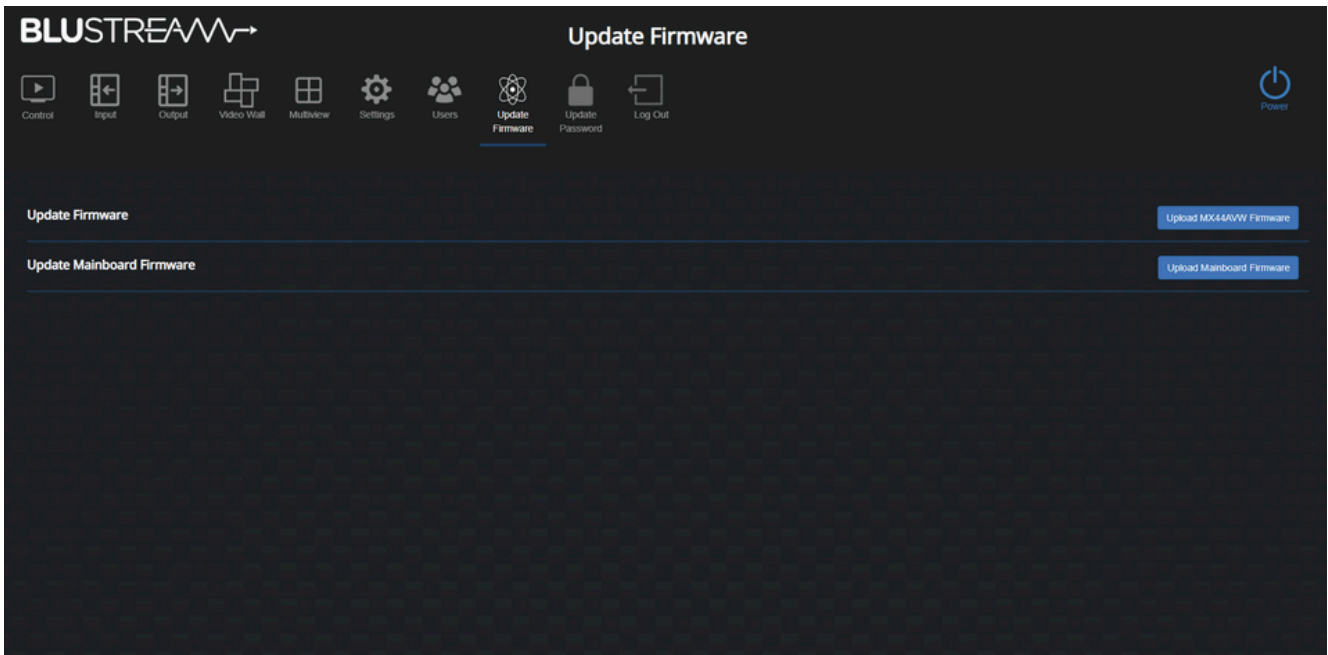

When updating the firmware normally, use the Update MX44AVW Firmware option. Ensure you have the correct firmware file and press the corresponding button. This will open a sub menu where you can browse for the firmware file on your device.

Once the file has been uploaded, press the Upload button to start the update.

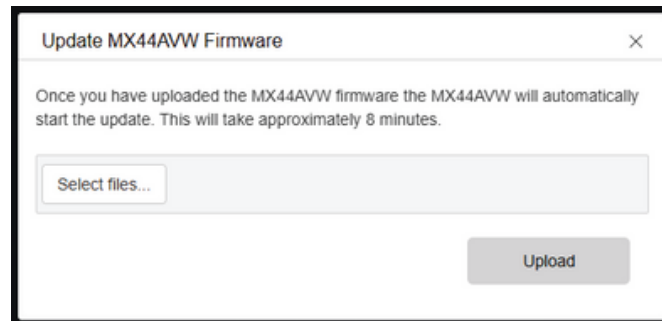

If the update has failed, RS-232 is not responsive but the web-GUI is accessible, use the Upload Mainboard Firmware option.

Please note: This option is for recovery only and should not be used otherwise.

Ensure you have the correct firmware file and press the corresponding button. This will open a sub menu where you can browse for the firmware file on your device. Once the file has been uploaded, press the Upload button to start the update.

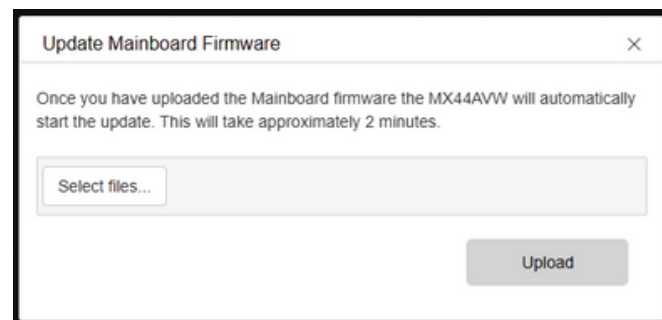

Specifications

- **Video Input Connectors:** 4 x HDMI Type A, 19-pin, female
- **Video Output Connectors:** 4 x HDMI Type A, 19-pin
- **Audio Input Connectors:** 5-Pin Phoenix connector (2ch balanced/un-balanced analogue audio)
- **Audio Output Connectors:** 1 x Optical (S/PDIF), 5-Pin Phoenix connector (2ch balanced/un-balanced analogue audio)
- **Control ports:** 1 x DB-9, female
- **Console control ports:** 1 x USB Type C, female
- **TCP/IP Control:** 1 x RJ45, female
- **IR Input ports:** 5 x 3.5mm stereo jack
- **IR Output ports:** 4 x 3.5mm mono jack
- **Firmware Upgrade:** 1 x USB Type A female
- **Rack-Mountable:** 1U rack height, rack ears included
- **Casing Dimensions (W x D x H):** 440mm x 240mm x 44mm
- **Dimensions Including Connections (W x D x H):** 440mm x 245mm x 44mm
- **Shipping Weight:** 5.3kg
- **Operating Temperature:** 32°F to 104°F (0°C to 40°C)
- **Storage Temperature:** -4°F to 140°F (-20°C to 60°C)
- **Power Supply:** Internal 100-240V AC

NOTE:

Specifications are subject to change without notice. Weights and dimensions are approximate.

Package Contents

- 1 x MX44AVW
- 1 x Remote control
- 1 x IR Control Cable - 3.5mm-3.5mm Cable
- 1 x 19" Rack Mounting kit
- 4 x Mounting feet
- 1 x Quick Reference Card
- 1 x IEC Power Cable

Maintenance

Clean this unit with a soft, dry cloth. Never use alcohol, paint thinner or benzene to clean this unit.

RS-232 Configuration and Telnet Commands

The MX44AVW can be controlled via serial and TCP/IP.

The default RS-232 communication settings are:

Baud rate:

57600 Data bits:

8 Stop bits: 1

Parity bit: none

The following pages list all available serial / IP commands.

Commonly Used Serial Commands

There are several commands that are commonly used for control and testing:

STATUS Status will give feedback on the switcher such as outputs on, type of connection, etc.

PON Power on Power off Toggling the main output

POFF ON or OFF as required

OUTON/OFF

Example: OUTON (This would turn the main output on)

OUT FRyy (yy is the input)

Example: OUT FR04 (This would switch the main output to source input 4)

Common Mistakes

- Carriage return: Some programs do not require the carriage return where as other will not work unless sent directly after the string. In the case of some Terminal software the token <CR> is used to execute a carriage return. Depending on the program you are using this token maybe different. Some other examples that other control systems deploy include \r or 0D (in hex)
- Spaces: Blustream commands do not require space between commands unless specified. There may be some programs that require spacing in order to work.
 - How the string should look is as follows: OUTON
 - How the string may look if spaces are required: OUT{Space}ON
- Baud rate or other serial protocol settings not correct

RS-232 Configuration and Telnet Commands (continued)

COMMAND	ACTION
?	Print Help Information Print Help
HELP	Information Print System Status And Port
STATUS	Status Print All Soft Version Power On,
FWVER	System Run On Normal State Power Off,
PON	System Run On Power Save State Set
POFF	System And Network Reboot Set System IR
REBOOT	Control On Or Off Set System KEY Control
IR ON/OFF	On Or Off
KEY ON/OFF	Set Power LED Light Up Time
LED xx yy	xx=PON: When Device Is Powered On xx=POFF: When Device Is Powered Off yy=OFF: Set Power LED To Always Off yy=15: Set Power LED To Auto Turn Off After 15sec yy=30: Set Power LED To Auto Turn Off After 30sec yy=60: Set Power LED To Auto Turn Off After 60sec yy=ON: Set Power LED To Always On
RSB x	Set RS232 Baud Rate To x bps
RESET	Reset System To Default Setting
RESET ALL	Reset System And Network To Default Setting (Should Type "Yes" To Confirm, "No" To Discard)
MODE oo	Set Device mode oo=[00]: Matrix mode oo=[01]: VideoWall mode oo=[02]: Multiview mode
OUT oo ON/OFF	Set Output On Or Off
OUT oo FR ii	Set Output:oo From Input:ii oo=[00]: Select All Output Port oo=[01...04]: Select One Output Port ii=[01...04]: Select One Input Port
OUT xx BRIGHTNESS yy	Set Output xx Brightness To yy xx=[01...04]: Select One Output Port yy=[0...255]: Brightness Value
OUT xx SATURATION yy	Set Output xx Saturation To yy xx=[01...04]: Select One Output Port yy=[0...255]: Saturation Value
OUT xx CONTRAST yy	Set Output xx Contrast To yy xx=[01...04]: Select One Output Port yy=[0...255]: Contrast Value
OUT xx HUE yy	Set Output xx Hue To yy xx=[01...04]: Select One Output Port yy=[0...255]: Hue Value

COMMAND	ACTION
OUT oo SCALING yy	Set Output Video Mode yy oo=[00]: Select All Output Port oo=[01...04]: Select One Output Port yy=[01]: 4096x2160p60Hz yy=[02]: 4096x2160p59Hz yy=[03]: 4096x2160p50Hz yy=[04]: 4096x2160p30Hz yy=[05]: 4096x2160p29Hz yy=[06]: 4096x2160p25Hz yy=[07]: 4096x2160p24Hz yy=[08]: 4096x2160p23Hz yy=[09]: 3840x2160p60Hz(2160p60) yy=[10]: 3840x2160p59Hz(2160p59) yy=[11]: 3840x2160p50Hz(2160p50) yy=[12]: 3840x2160p30Hz(2160p30) yy=[13]: 3840x2160p29Hz(2160p29) yy=[14]: 3840x2160p25Hz(2160p25) yy=[15]: 3840x2160p24Hz(2160p24) yy=[16]: 3840x2160p23Hz(2160p23) yy=[17]: 1920x1080p60Hz(1080p60) yy=[18]: 1920x1080p59Hz(1080p59) yy=[19]: 1920x1080p50Hz(1080p50) yy=[20]: 1920x1080p30Hz(1080p30) yy=[21]: 1280x720p60Hz(720p60)
OUT oo HDCP BYP/ V14/ V 2 2	Set HDCP overrider mode To Output ooo
OUT oo NAME name	Set Output Name to name
IN oo NAME name	Set Input Name to name
AUDIO xx FR yy	Set Audio Output xx From Input yy xx = 00 : All Outputs xx = [01-04] : HDMI Output 1 - 4 xx = [05]: Analogue and Optical Audio Output yy = [01-04] : Audio From HDMI Input 1-4 yy = [05] : Analogue Audio Input
AUDOUT xx mm	Turn Mute On/Off On Output xx mm = On mm = Off xx = 00 : All Outputs xx = [01-04] : HDMI Output 1 - 4 xx = [05]: Analogue and Optical Audio Output
AUDIN GAIN vv yy	Set Input: xx Gain To yy vv=[L, R or LR] This Is Optional. If L Or R Is Not Specified Then Both Channels Are Adjusted yy=[-12...40]: Gain Value (dB) (Step=0.5)
EDID xx CP yy	Set Input:xx EDID Copy From Output:yy xx=00: Select All Input Port xx=[01...04]: Select One Input Port yy=[01...04]: Select One Loopout Port yy=05: Select Output Port

RS-232 Configuration and Telnet Commands (continued)

COMMAND	ACTION
EDID xx DF zz	<p>Set Input:xx EDID To Default EDID:zz</p> <p>xx=00: Select All Input Port xx=[01...04]: Select One Input Port zz=00: HDMI 1080p@60Hz, Audio 2CH PCM (default) zz=01: HDMI 1080p@60Hz, Audio 5.1CH DTS/DOLBY zz=02: HDMI 1080p@60Hz, Audio 7.1CH DTS/DOLBY/HD zz=03: HDMI 1080i@60Hz, Audio 2CH PCM zz=04: HDMI 1080i@60Hz, Audio 5.1CH DTS/DOLBY zz=05: HDMI 1080i@60Hz, Audio 7.1CH DTS/DOLBY/HD zz=06: HDMI 1080p@60Hz/3D, Audio 2CH PCM zz=07: HDMI 1080p@60Hz/3D, Audio 5.1CH DTS/DOLBY zz=08: HDMI 1080p@60Hz/3D, Audio 7.1CH DTS/DOLBY/HD zz=09: HDMI 4K@30Hz 4:4:4, Audio 2CH PCM zz=10: HDMI 4K@30Hz 4:4:4, Audio 5.1CH DTS/DOLBY zz=11: HDMI 4K@30Hz 4:4:4, Audio 7.1CH DTS/DOLBY/HD zz=12: HDMI 4K@60Hz 4:2:0/4K@30Hz 4:4:4, Audio 2CH PCM zz=13: HDMI 4K@60Hz 4:2:0/4K@30Hz 4:4:4, Audio 5.1CH DTS/DOLBY zz=14: HDMI 4K@60Hz 4:2:0/4K@30Hz 4:4:4, Audio 7.1CH DTS/DOLBY/HD zz=15: HDMI 4K@60Hz 4:4:4, 8-bit, Audio 2CH PCM zz=16: HDMI 4K@60Hz 4:4:4, 8-bit, Audio 5.1CH DTS/DOLBY zz=17: HDMI 4K@60Hz 4:4:4, 8-bit, Audio 7.1CH DTS/DOLBY/HD zz=30: DVI 1280x1024@60Hz, Audio None zz=31: DVI 1920x1080@60Hz, Audio None zz=32: DVI 1920x1200@60Hz, Audio None zz=33: DVI 1920x1200@60Hz, Audio 5.1CH zz=34: EDID Pass-through (Copy From Output1) zz=35: EDID Pass-through (Copy From Output2) zz=36: EDID Pass-through (Copy From Output3) zz=37: EDID Pass-through (Copy From Output4) zz=38: User EDID 1 zz=39: User EDID 2</p>
VW PRESET pp NAME name	<p>Set Video Wall Name to name pp=[01..8]: Select Preset Index name: Max 16 char</p>
VW LAYOUT xx FR ii	<p>Set Output Layout Index:xx From Input:aa/bb/cc/dd xx=[01..12]: Select Layout Index ii=[01...04]: Select One Input Port For Video Wall Source</p>

COMMAND	ACTION
VW PRESET pp LAYOUT USER <x1,y1,h1,v1,r1> <x2,y2,h2,v2,r2> <x3,y3,h3,v3,r3> <x4,y4,h4,v4,r4> FR ii	<p>Set Preset:pp Layout To User Defined:<x,y,h,v> From Input:aa/bb/cc/dd</p> <p>x=[00...4095]: X Coordinate Of Window 1/2/3/4 Top-left Corner y=[00...2159]: Y Coordinate Of Window 1/2/3/4 Top-left Corner h=[00...4095]: The Horizontal Size Of Window 1/2/3/4 v=[00...2159]: The Vertical Size Of Window 1/2/3/4 r=[00..360]: The Angle Rotation Of Window 1/2/3/4 ii=[01...04]: Select One Input Port For Video Wall Source</p>
VW PRESET pp STATUS	<p>Print Preset pp Config Status pp - 1~8</p>
VW PRESET pp SAVE	<p>Save Current Config To Preset:pp pp=[01..08]: Select Preset Index</p>
VW PRESET pp APPLY	<p>Apply Preset:pp Config pp=[01..08]: Select Preset Index</p>
VW LAYOUT xx USER <x1,y1,w1,h1,r1>	<p>Set Output:xx Layout To User Defined:<x,y,h,v> x=[00...4095]: X Coordinate Of Crop Window Top-left Corner y=[00...2159]: Y Coordinate Of Crop Window Top-left Corner h=[00...4095]: The Horizontal Size Of Crop Window v=[00...2159]: The Vertical Size Of Crop Window r=[00..360]: The Angle Rotation Of Crop Window</p>
VW FR ii	<p>ii=[01...04]: Select One Input Port For Video Wall Source</p>
VW AUDIO FR yy	<p>yy=[00]: Video Wall audio follow video Source yy=[01...04]: Video Wall audio set to HDMI 1 ~ 4 yy=[05]: Video Wall audio set to analogy input</p>
MV mm WIN xx FR yy	<p>Set Multiview mm WIN xx From yy mm=[01..02]: Select Multiview Index xx=[00]: Select All Window xx=[01..04]: Select Window number 1 ~ 4 yy=[01...04]: Select One Input Port 1 ~ 4</p>
MV mm LAYOUT xx FR aa bb cc dd	<p>Set Output Layout Index:xx From Input:aa/bb/cc/dd mm=[01..02]: Select Multiview Index xx=[01..16]: Select Layout Index aa=[01...04]: Select One Input Port For Window 1 Source bb=[01...04]: Select One Input Port For Window 2 Source cc=[01...04]: Select One Input Port For Window 3 Source dd=[01...04]: Select One Input Port For Window 4 Source</p> <p>Note: aa, bb, cc, dd are optional</p>

RS-232 Configuration and Telnet Commands (continued)

COMMAND	ACTION
MV mm LAYOUT USER <x1,y1,h1,v1> <x2,y2,h2,v2> <x3,y3,h3,v3> <x4,y4,h4,v4> FR aa bb cc dd	Set Output Layout To User Defined:<x,y,h,v> From Input:aa/bb/cc/dd mm=[01..02]: Select Multiview Index x=[00...4095]: X Coordinate Of Window 1/2/3/4 Top-left Corner y=[00...2159]: Y Coordinate Of Window 1/2/3/4 Top-left Corne h=[00...4095]: The Horizontal Size Of Window 1/2/3/4 v=[00...2159]: The Vertical Size Of Window 1/2/3/4 aa=[01...04]: Select One Input Port For Window 1 Source bb=[01...04]: Select One Input Port For Window 2 Source cc=[01...04]: Select One Input Port For Window 3 Source dd=[01...04]: Select One Input Port For Window 4 Source Note: aa, bb, cc, dd are optional
MV mm AUDIO FR yy	Set Output Audio From Input yy mm=[01...04]: Select One Output Port yy=[01...04]: Select One Input Port yy=[05]: Analogy Input
MV mm PRESET pp NAME name	Set Multiview Name to name mm=[01..02]: Select Multiview Index pp=[01..8]: Select Preset Index name: Max 16 char
MV mm PRESET pp LAYOUT xx FR aa bb cc dd	Set Preset:pp To Layout Index:xx From Input:aa/bb/cc/dd mm=[01..02]: Select mv Index pp=[01..08]: Select Preset Index xx=[01..05]: Select Layout Index aa=[01...04]: Select One Input Port For Window 1 Source bb=[01...04]: Select One Input Port For Window 2 Source cc=[01...04]: Select One Input Port For Window 3 Source dd=[01...04]: Select One Input Port For Window 4 Source
MV mm PRESET pp LAYOUT USER <x1,y1,h1,v1> <x2,y2,h2,v2> <x3,y3,h3,v3> <x4,y4,h4,v4> FR aa bb cc dd	Set Preset:pp Layout To User Defined:<x,y,h,v> From Input:aa/bb/cc/dd mm=[01..02]: Select Multiview Index x=[00...4095]: X Coordinate Of Window 1/2/3/4 Top-left Corner y=[00...2159]: Y Coordinate Of Window 1/2/3/4 Top-left Corne h=[00...4095]: The Horizontal Size Of Window 1/2/3/4 v=[00...2159]: The Vertical Size Of Window 1/2/3/4 aa=[01...04]: Select One Input Port For Window 1 Source bb=[01...04]: Select One Input Port For Window 2 Source cc=[01...04]: Select One Input Port For Window 3 Source dd=[01...04]: Select One Input Port For Window 4 Source
MV mm PRESET STATUS	Print Preset Config Status

COMMAND	ACTION
MV mm PRESET pp SAVE	Save Current Config To Preset:pp pp=[01..08]: Select Preset Index
MV mm PRESET pp A PPLY	Apply Preset:pp Config pp=[01..08]: Select Preset Index
NET STATUS	Show NET Settings
NET DHCP ON/OFF	Set Auto IP(DHCP) On Or Off
NET IP xxx.xxx.xxx.xxx	Set IP Address
NET GW xxx.xxx.xxx.xxx	Set Gateway Address
NET SM xxx.xxx.xxx.xxx	Set Subnet Mask Address
NET TCPPORT xxxx	Set TCP/IP Port
NET TCPPORT ON/OFF	Set TCP/IP On Or Off
NET TN xxxx	Set Telnet Port
NET TN ON/OFF	Set Telnet On Or Off
NET WEB ON/OFF	Set Web Access On Or Off
NET HTTPS ON/OFF	Set Https Access On Or Off
NET RB	Set Network Reboot And Apply New Config!!!
NET DNS xxxx	Set DNS Domain Name To xxxx

Certifications

FCC Notice

This equipment has been tested and found to comply with the limits for a Class B digital device, pursuant to part 15 of the FCC Rules. These limits are designed to provide reasonable protection against harmful interference in a residential installation. This equipment generates, uses, and can radiate radio frequency energy and, if not installed and used in accordance with the instructions, may cause harmful interference to radio communications. However, there is no guarantee that interference will not occur in a particular installation. If this equipment does cause harmful interference to radio or television reception, which can be determined by turning the equipment off and on, the user is encouraged to try to correct the interference by one or more of the following measures:

- Reorient or relocate the receiving antenna.
- Increase the separation between the equipment and receiver.
- Connect the equipment into an outlet on a circuit different from that to which the receiver is connected.
- Consult the dealer or an experienced radio/TV technician for help.

CAUTION - changes or modifications not expressly approved by the party responsible for compliance could void the user's authority to operate the equipment.

CANADA, INDUSTRY CANADA (IC) NOTICES

This Class B digital apparatus complies with Canadian ICES-003.

Operation is subject to the following two conditions: (1) this device may not cause interference, and (2) this device must accept any interference, including interference that may cause undesired operation of the device.

CANADA, AVIS D'INDUSTRY CANADA (IC)

Cet appareil numérique de classe B est conforme aux normes canadiennes ICES-003.

Son fonctionnement est soumis aux deux conditions suivantes : (1) cet appareil ne doit pas causer d'interférence et (2) cet appareil doit accepter toute interférence, notamment les interférences qui peuvent affecter son fonctionnement.

CORRECT DISPOSAL OF THIS PRODUCT

This marking indicates that this product should not be disposed with other household wastes. To prevent possible harm to the environment or human health from uncontrolled waste disposal, recycle it responsibly to promote the sustainable reuse of material resources. To return your used device, please use the return and collection systems or contact the retailer where the product was purchased. They can take this product for environmentally safe recycling.



BLUSTREAM 