

# ► DMP168

## User Manual

Thank you for purchasing this product.

For optimum performance and safety, please read these instructions carefully before connecting, operating or adjusting this product. Please keep this manual for future reference.



### Surge Protection Device Recommended

This product contains sensitive electrical components that may be damaged by electrical spikes, surges, electric shock, lightning strikes, etc. Use of surge protection systems is highly recommended in order to protect and extend the life of your equipment.



### Eco Friendly Packaging

This product has been packaged with fully recyclable materials, including compostable bags. Please help us to help the environment.

# Contents

Introduction	03
Front Panel Description	03
Rear Panel Description	04
Resetting the DMP168	04
Operation and Connections	04
Web-GUI - Log In and Initialisation	05
Web-GUI - Control	06-09
Web-GUI - Input	10
Web-GUI - Bus	11-13
Web-GUI - Output	14-15
Web-GUI - DSP	16-17
Web-GUI - Trigger	18
Web-GUI - Preset	19-20
Web-GUI - Users	20-21
Web-GUI - Settings	22
Web-GUI - System	23-24
Web-GUI - Information	24
Specifications	25
Package Contents	25
Maintenance	25
Schematic	26
RS-232 Config and Telnet Commands	27-30
Certifications	31

## Introduction

The Blustream DMP168 is an advanced 16x8 digital audio matrix, perfect for the distribution of multiple audio sources in a multizone installation.

The DMP168 features advanced audio processing including volume, balance, high/low shelf, high/low pass filter and 4 band parametric equalizer control per input and output, independent lip-sync delay per input, stereo to mono separation, or combining of mono audio inputs, configurable output grouping, and assignable audio ducking.

The DMP168 provides an advanced, but cost effective solution for ensuring that 2ch audio can be distributed around a multi-room system where there are a mixture of digital and analogue audio sources.

---

### FEATURES:

- 8 x analogue L/R inputs, 4 x digital coaxial inputs, and 4 x digital optical inputs which can be switched to 8 x analogue L/R outputs
- Supports separation (mono) of all audio channels and independent control resulting in switching of up to 32x16 audio feeds
- Supports: volume, balance, high/low shelf, high/low pass filter, and 4 band parametric equalizer control per input and output
- Supports independent gain adjustment for all analogue and digital inputs
- Features 8 x assignable bus inputs allowing mixing of source inputs
- Features output grouping to combine audio outputs for a single group control. Combining the output grouping feature with high/low pass filter results in up to 4 x 2.1ch audio outputs
- Features assignable audio ducking with independent level and ramp up/down rate adjustment
- Features 8x configurable presets
- Supports 48kHz 24-bit sampling rate for A/D and D/A conversion
- Digital audio inputs support resolutions up to 192kHz 24-bit
- Supports independent lip-sync delay (0-500ms) per output
- Features input audio sensing, 2 x contact closures and 2 x trigger inputs allowing programmable events based on the presence of audio, NO/NC connections, and/or voltage between 2-15V AC or DC voltage

---

## Front Panel Description

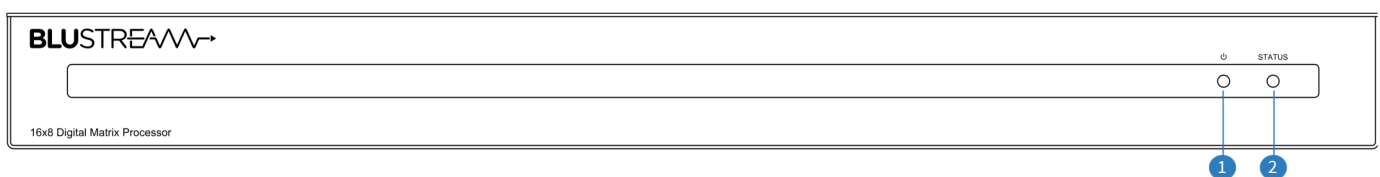

- 1 Power LED indicator
- 2 Status LED indicator

## Rear Panel Description

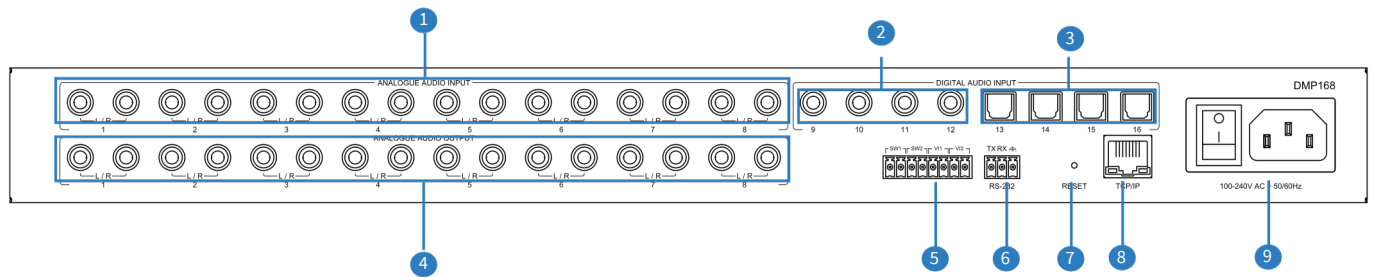

- 1 8 x Analogue RCA Inputs
- 2 4 x Digital RCA (S/PDIF) Inputs
- 3 4 x Optical (S/PDIF) Inputs
- 4 8 x Analogue RCA Outputs
- 5 4 x 2 pin Phoenix connector
- 6 RS-232 3 pin Phoenix connector
- 7 Reset Switch
- 8 TCP/IP RJ45 Port
- 9 Mains C14 IEC Power Inlet

## Resetting the DMP168

To reset the DMP168 back to factory default, use a small instrument to press down the recessed button on the back of the unit labelled RESET. Hold for at least 10 seconds before releasing.

The reset process takes approximately 30 seconds.

## Operation and Connections

The DMP168 is operated by using the in-built Web-GUI. Connect the input and output devices, the TCP/IP port, and power to the rear of the unit.

## Web-GUI - Log In and Initialisation

The following pages will take you through the operation of the units web-GUI. You must connect the TCP/IP RJ45 socket to your local network, or directly from your computer to the DMP168, in order to access the product's web-GUI.

By default, the unit is set to DHCP; however, if a DHCP server (eg: network router) is not installed, the unit's IP address will revert to below details:

Default IP Address is: [192.168.0.200](#)

Default Admin Username is: [blustream](#)

Default Admin Password is: [@BlS1234](#)

The DMP168 is able to be accessed via the Domain name if the IP address is not known:

Default mDNS is: [dmp168.local](#)

### Login Page:

The web-GUI supports multiple users along with multiple user permissions as follows:

- Admin (Blustream)                      The Admin account allows full access to all functions and configuration of the unit.
- User Accounts                              User accounts can be utilised, each with individual login detail and can be assigned permissions to specific areas and functions.
- Guest    When enabled, the Guest user can access the control page without logging in.

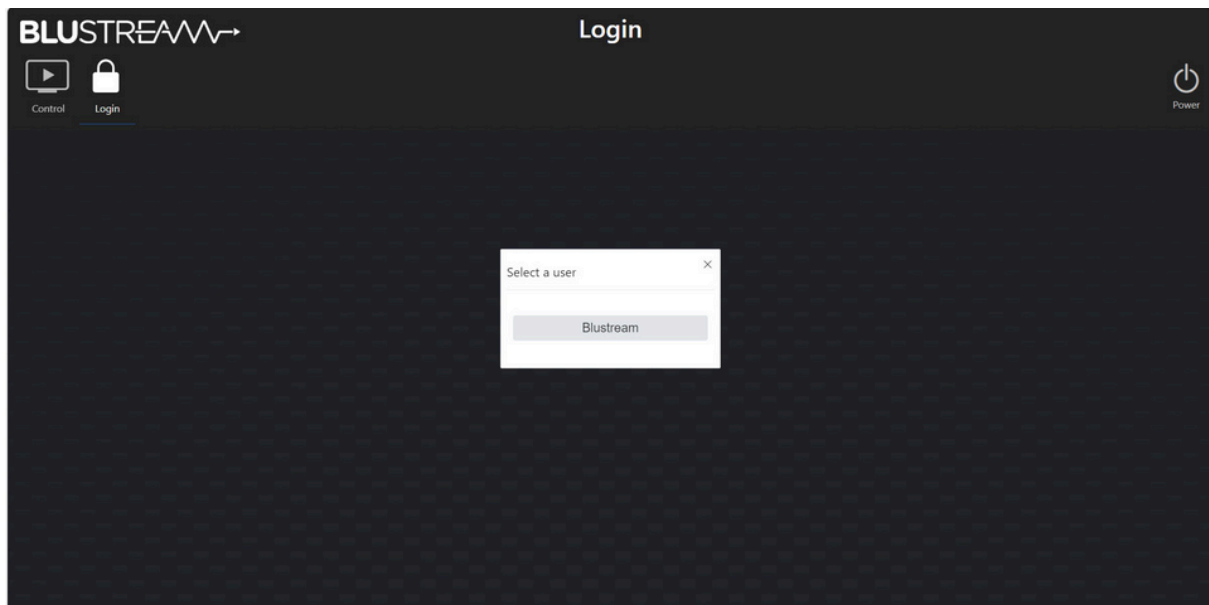

Please note: the first time the Administrator logs into the web-GUI of the DMP168, the default password must be changed to a unique password. Please retain this password for future use. Forgetting the password will mean having to factory reset the unit, losing all configuration settings. Passwords can be changed as required within the web-GUI of the unit once logged in.

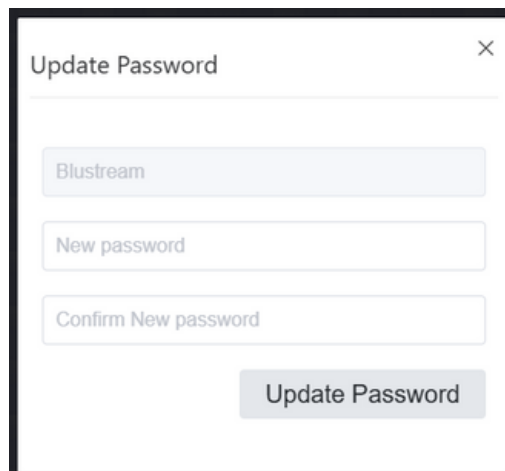

# Web-GUI - Control

After logging into the DMP168, the user will be directed to the Control page. Configuration of the matrix can be done here, as well as adjusting levels for inputs, outputs, buses and groups, and recalling presets as needed.

Please note: Changes made in the Control page, and in other pages will be reflected globally. They will be updated in the respective section of the Control page.

In the upper right corner, the DSP utilisation percentage is displayed. Utilising the DSP features will lead to an increase in this percentage; if it rises too high, audio distortion may occur. It is crucial to keep an eye on the DSP utilisation to ensure it remains below 93%. A reference chart indicating the percentage increases is provided below:

Function	DSP Utilization Percentage
Default function	17%
Volume / Mute Control	9%
Audio Bus Mixing	0.164% per mono channel of mixing
Audio Ducking	3%
Audio Delay	7%
Input Crossover/EQ/Shelf Filter	0.5% per filter per channel
Output Crossover/EQ/Shelf Filter	0.5% per filter per channel

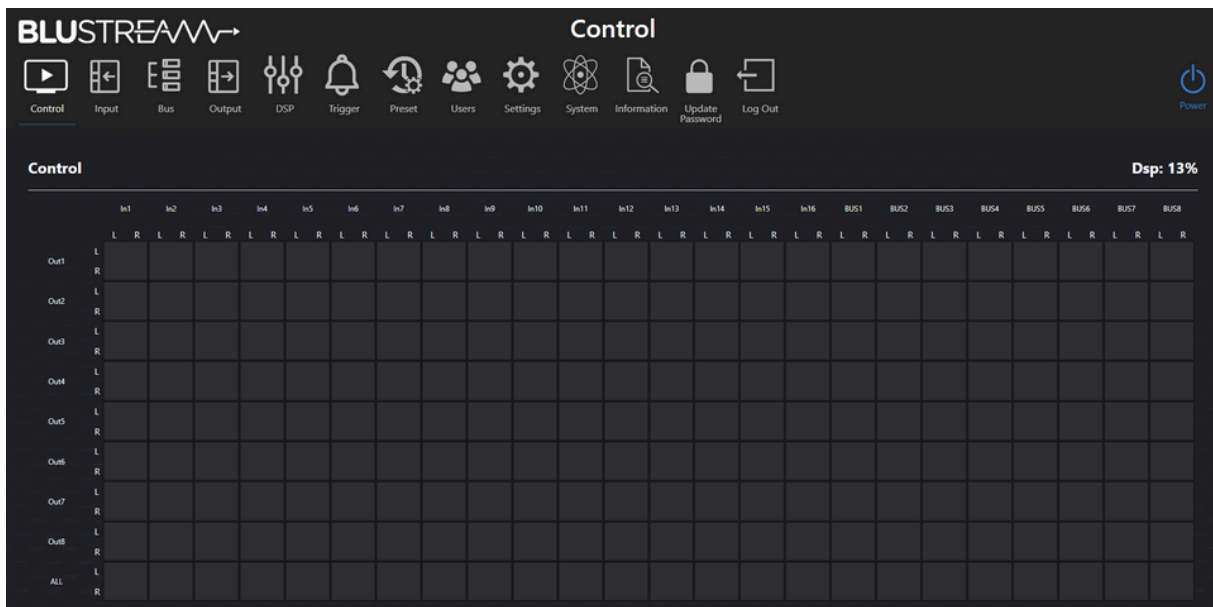

**Control (Matrix):** For any audio sources connected to be able to output a signal, it must be routed in the Control page Matrix. Input channels are listed as columns along the x-axis, and output channels are listed as rows along the y-axis. The last right most 8 columns in the matrix are reserved for the internal bus channels, enabling advanced audio routing options.

To route a signal, navigate the to the desired input channel. In the column under the input name, find the row that corresponds to the desired output channel, and press the button that intersects the desired column and row.

When a channel has enabled individual L&R control, the matrix will split that column’s or row’s buttons into a 2x2 grid to allow for the additional control options.

In the following examples, the x-axis will be labelled 1-24 left to right, and the y axis will be labelled 1-9 top to bottom. L&R individual controls will be labelled as the overall button and the sub button for the L&R row and column, following the previous numbering conventions (e.g., 1 1, 2S 2):

**Control Matrix (continued)**

- To route Input 1 to Output 1, select the button in position (1,1)

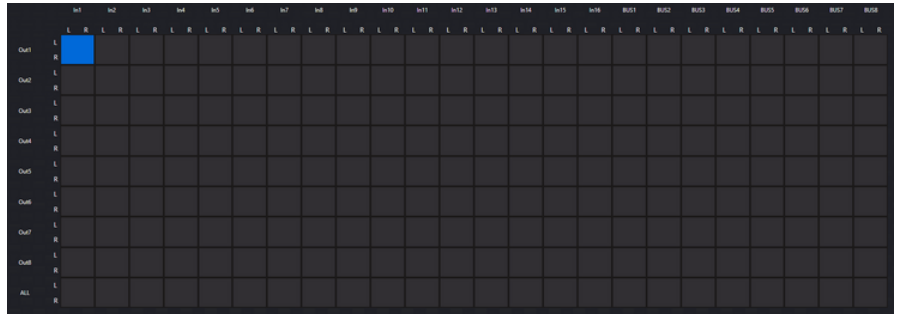

- To route Bus 6 to Output 8, select the button in position (22,8)

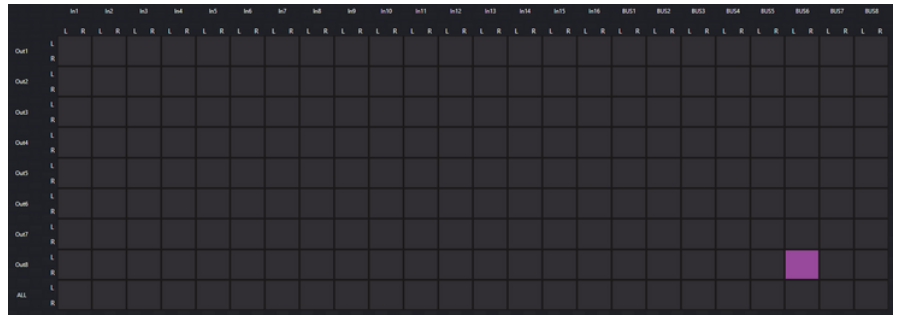

- To route the Left Channel of Input 3 to the Right Channel of Output 5, select the button in position (3S1,5S2)

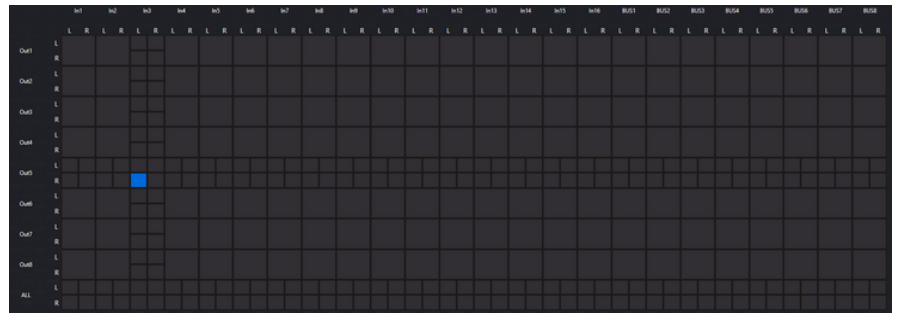

- To route Input 4 to All Outputs, select the button in position (4,9)

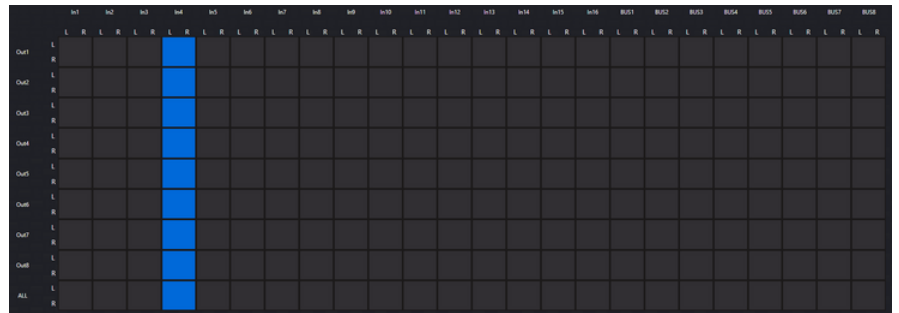

- To route an input to multiple outputs, select the desired outputs in that input's column
- To route multiple inputs to a single output, utilisation of the bus is required (see page 11)

**Levels:**

All levels sections feature the same controls for each of their respective channels. Volume can be set by moving the slider up or down.

Pressing the lock 1 will allow for individual left & right control of the channel (i.e., sending two separate mono signals on the same channel).

The volume can be fine tuned using the volume up 2 and volume down 4 buttons. It can also be manually set by typing directly into the volume field 3.

The input can be muted by pressing the mute button 5.

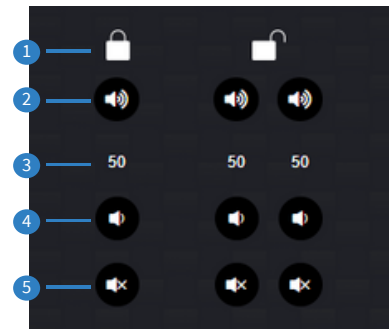

**Inputs:**

Allows for configuration of the 16 input channels; additional controls can be found in the Input page.

To quickly set all input channels to a desired configuration, set up input channel 1 then press **Apply IN1 to All Inputs**. This will apply the configuration from input channel 1 to all input channels.

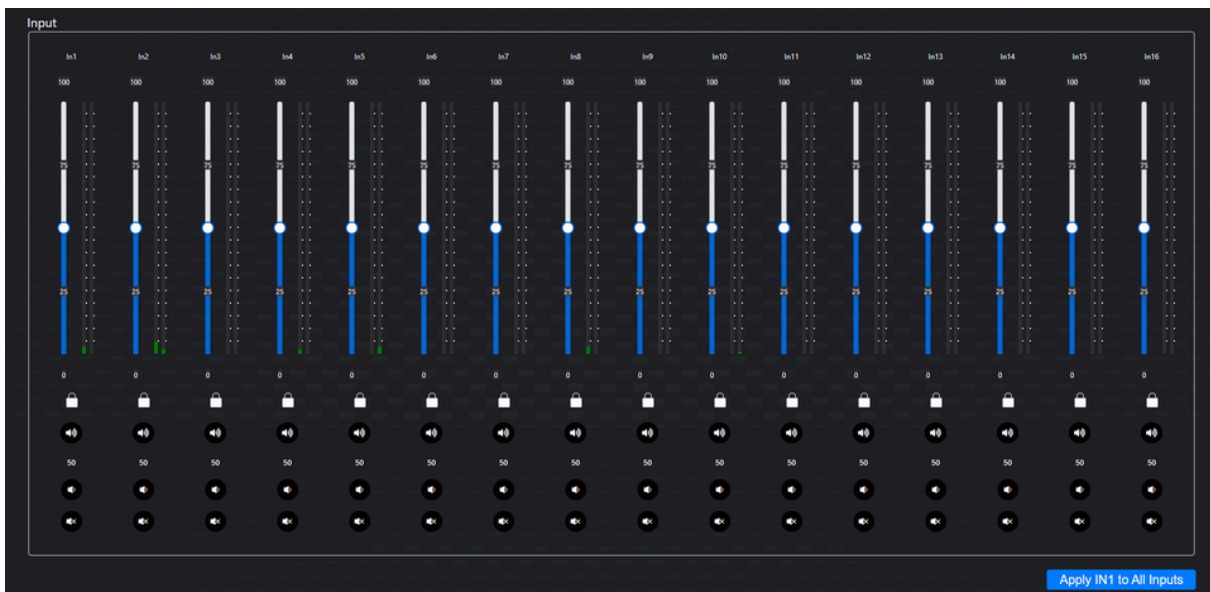

**Bus and Bus Master:** Allows for configuration of the 8 bus channels; additional controls can be found in the Bus page.

To quickly set all bus channels to a desired configuration, set up bus channel 1 then press **Apply BUS1 to All Buses**. This will apply the configuration from bus channel 1 to all bus channels.

Please note: 'Apply BUS1 to All Buses' will not affect the bus master channel.



**Output:**

Allows for configuration of the 8 output channels; additional controls can be found in the Output page.

To quickly set all output channels to a desired configuration, set up output channel 1 then press **Apply OUT1 to All Outputs**. This will apply the configuration from output channel 1 to all output channels.

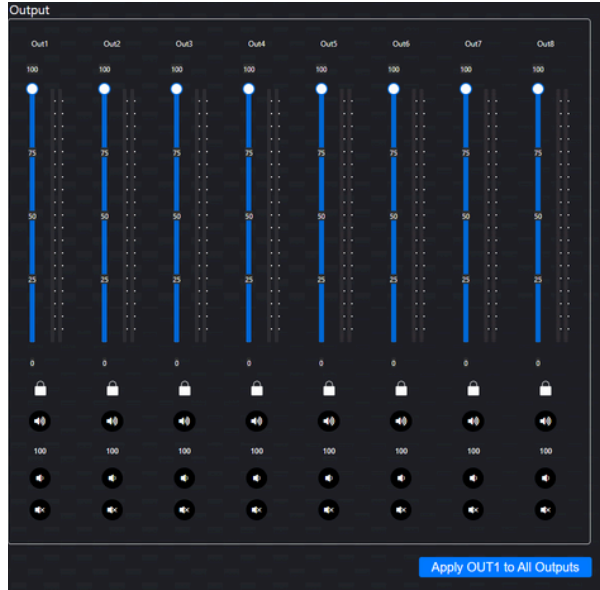

**Group and Group Master:**

Allows for configuration of the 4 group channels and the group master channel; additional controls can be found in the Output page.

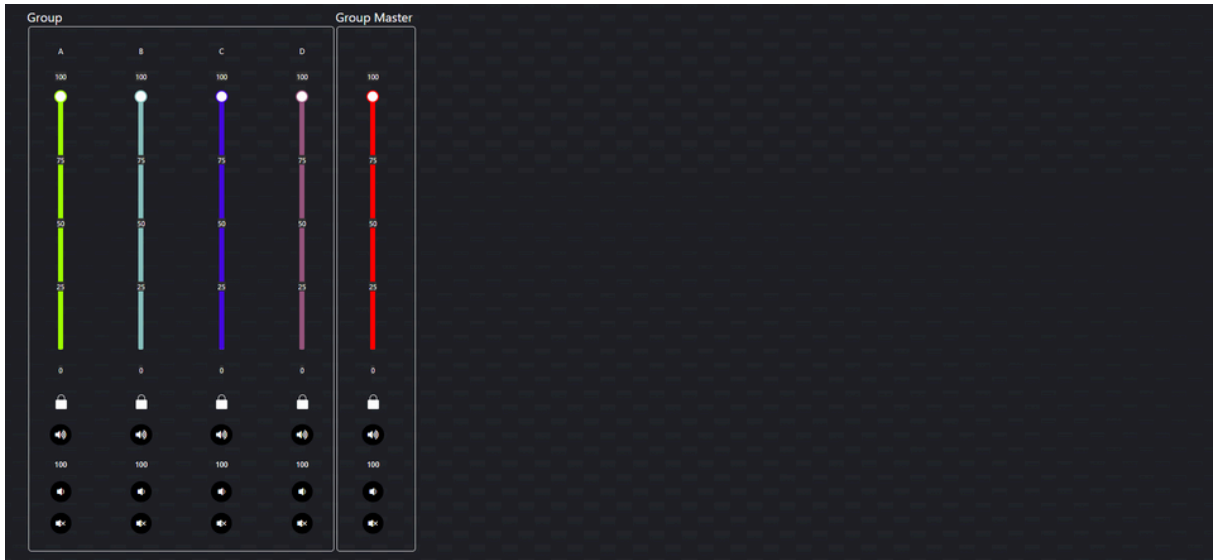

**Recall Preset:**

Allows up to 8 presets to be recalled, each with different configurations; these can be set up on the Preset page.

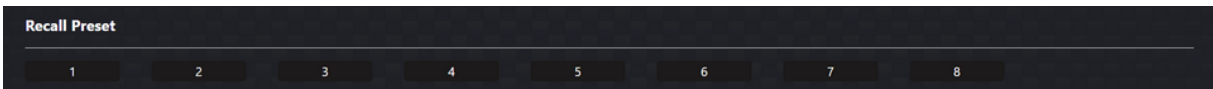

## Web-GUI - Input

The Input page features a mixer-style interface for volume and stereo control, muting, and renaming input channels.

To quickly set all input channels to a desired configuration, set up input channel 1 then press 'Apply IN1 to All Inputs'. This will apply the configuration from input channel 1 to all input channels.

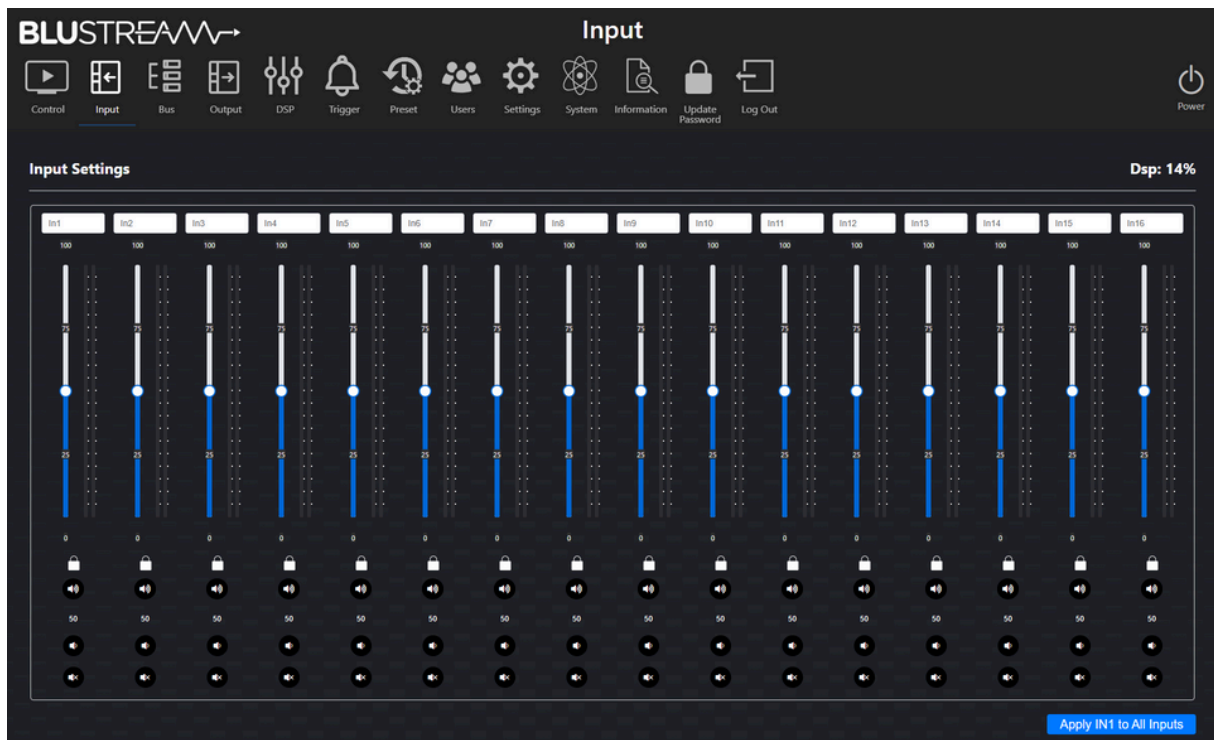

**Input Settings** (mixer control instructions can be found on page 08):

### Naming

- To set a name for an input, type a new name into the desired label for the corresponding input.

# Web-GUI - Bus

The DMP168 features a dedicated bus which comprises of 8 internal channels that enable advanced audio routing. The Bus page features a matrix for routing, and a mixer-style interface for volume and stereo control, muting, and renaming bus channels. It also features ducking control options.

To quickly set all bus channels to a desired configuration, set up bus channel 1 then press ‘Apply BUS1 to All Buses’. This will apply the configuration from bus channel 1 to all bus channels.

Please note: ‘Apply BUS1 to All Buses’ will not affect the bus master channel.

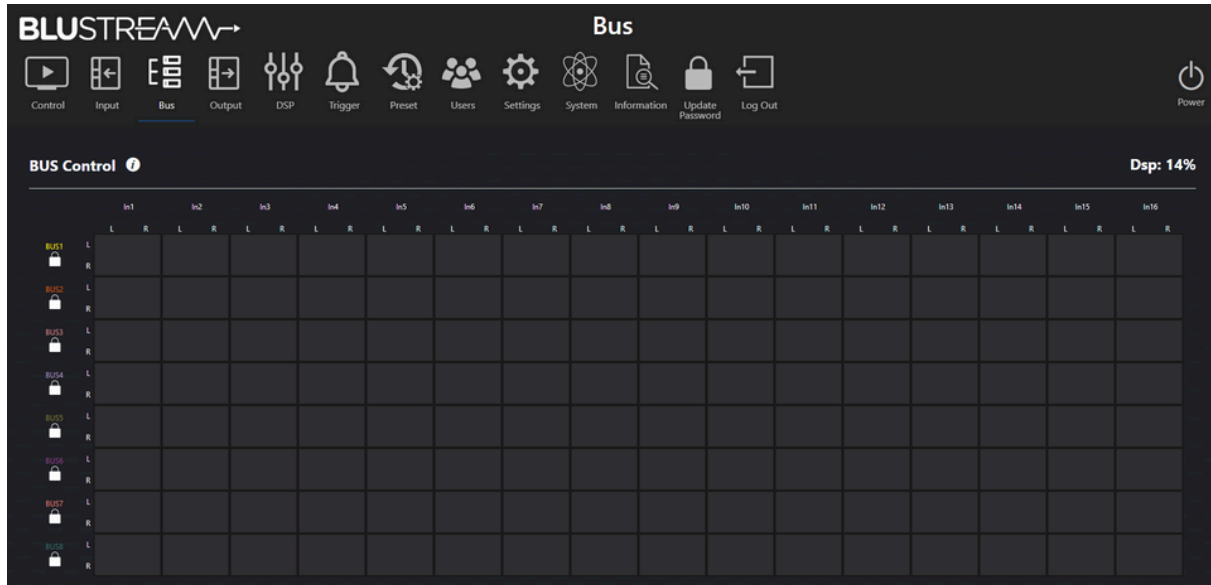

### Bus Control:

In order for a bus channel to output, it must be routed to an output channel via the Control page.

The input channels are listed as columns along the x-axis, and the bus channels are listed as rows along the y-axis.

To route a signal, navigate to the desired input channel. In the column under the input name, find the row that corresponds to the desired bus channel, and press the button that intersects the desired column and row.

When a channel has enabled individual L&R control, the matrix will split that column’s or row’s buttons into a 2x2 grid to allow for the additional control options.

In the following examples, the x-axis will be labelled 1-16 left to right, and the y axis will be labelled 1-8 top to bottom. L&R individual controls will be labelled as the overall button and the sub button for the L&R row and column, following the previous numbering conventions (e.g., 1S1, 2S2):

**Bus Control (continued)**

- To route Input 1 to Bus 1, select the button in position (1,1)

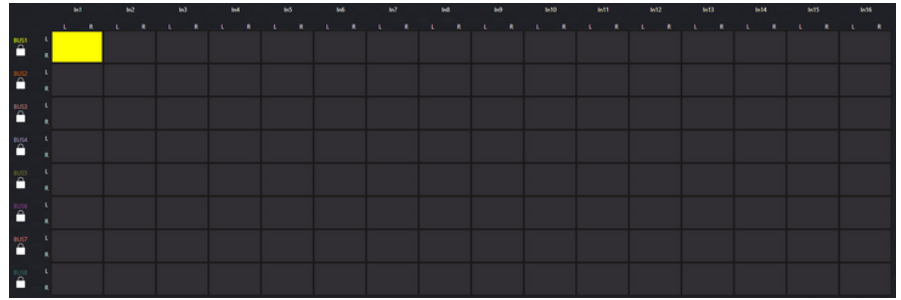

- To route Input 6 to Bus 8, select the button in position (6,8)

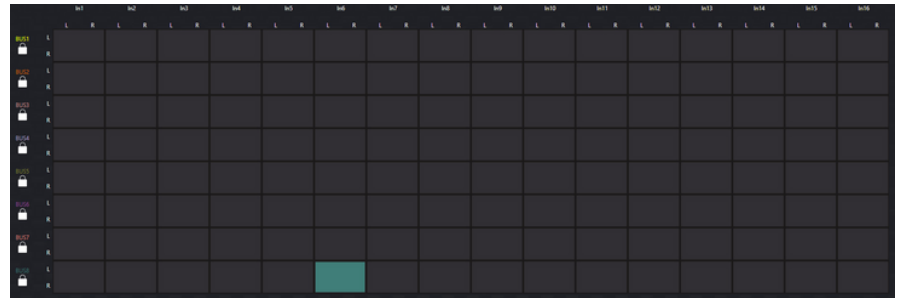

- To route the Left Channel of Input 3 to the right channel of Bus 5, select the button in position (3,5S2)

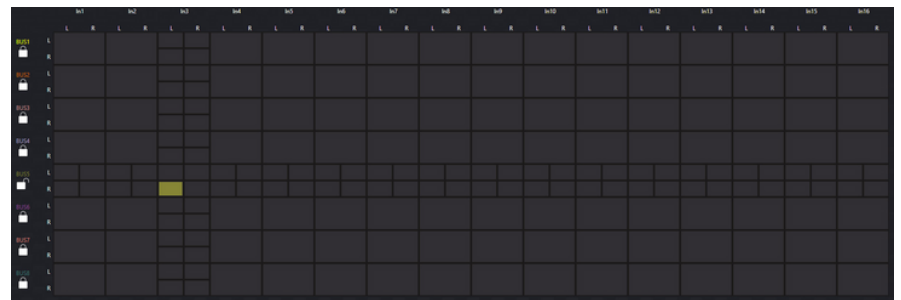

- To route all Input channels to Bus 7, select each button in row 7

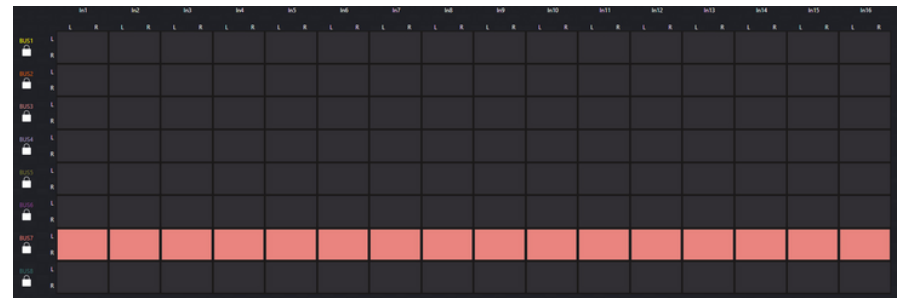

- To route an input channel to multiple bus channels, select the desired bus channels in that channel's column.
- To route a bus channel to multiple input channels, select the desired input channels in that channel's row.
  - If multiple input channels have been routed to a single bus channel, this can be routed to a single output channel in the matrix on the control page. In this way, it is possible to have multiple inputs routed to a single output.

**Bus Settings** (mixer control instructions can be found on page 08):

Naming

- To set a name for a bus, type a new name into the desired label for the corresponding bus.

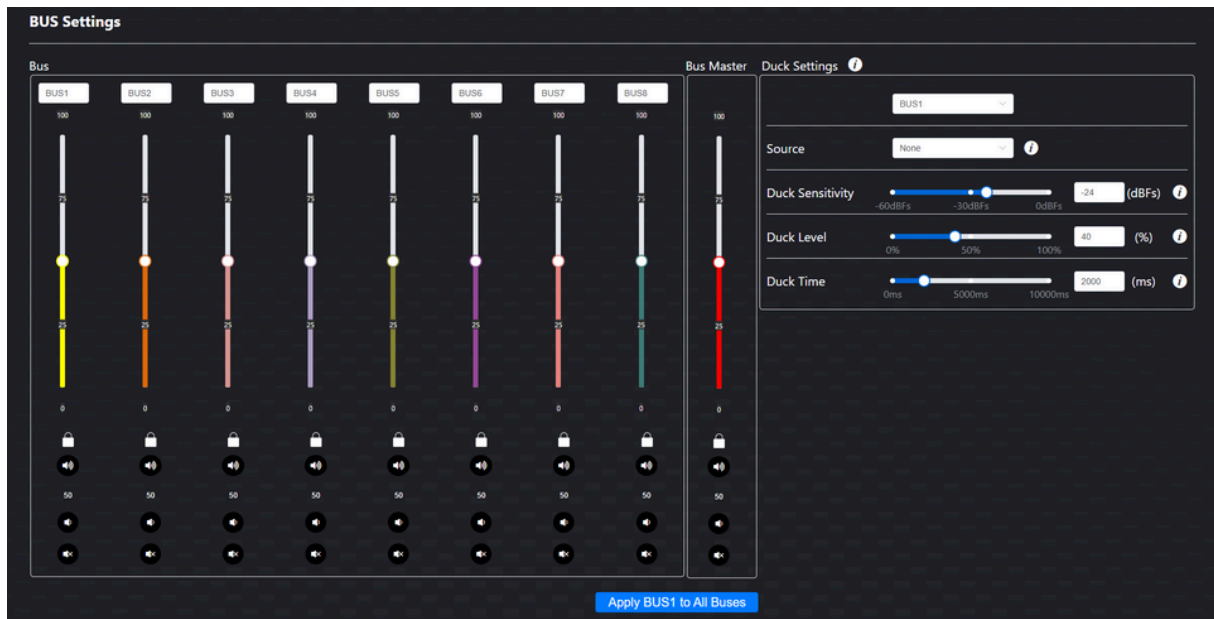

### Duck Settings

Ducking temporarily lowers, or “ducks,” the volume of a bus channels anytime a specified input channel is present. This could be used to lower background music anytime someone speaks into a microphone, and then raise it again when they finish speaking. Source ducking can be applied when multiple input channels have been routed to a bus channel.

Select the bus channel to apply the ducking feature to from the drop down menu:

Source

- Select the source channel that will trigger the ducking from the drop down menu

Duck Sensitivity

- Sets the threshold the source channel’s volume must reach to trigger the ducking. Use the slider to set this value, or manually input a value using the input field

Duck Level

- Sets the volume level all other channels will be set to when ducking is triggered. Use the slider to set this value, or manually input a value using the input field

Duck Time

- Sets the interval that the ducking will remain active for after the source channel’s volume falls below the sensitivity threshold. Use the slider to set this value, or manually input a value using the input field

## Web-GUI - Output

The Output page features a mixer-style interface for volume and stereo control, muting, and renaming channels as well options for output limiting, mono & stereo control, lip sync delay and grouping.

To quickly set all output channels to a desired configuration, set up output channel 1 then press 'Apply OUT1 to All Outputs'. This will apply the configuration from output channel 1 to all output channels.

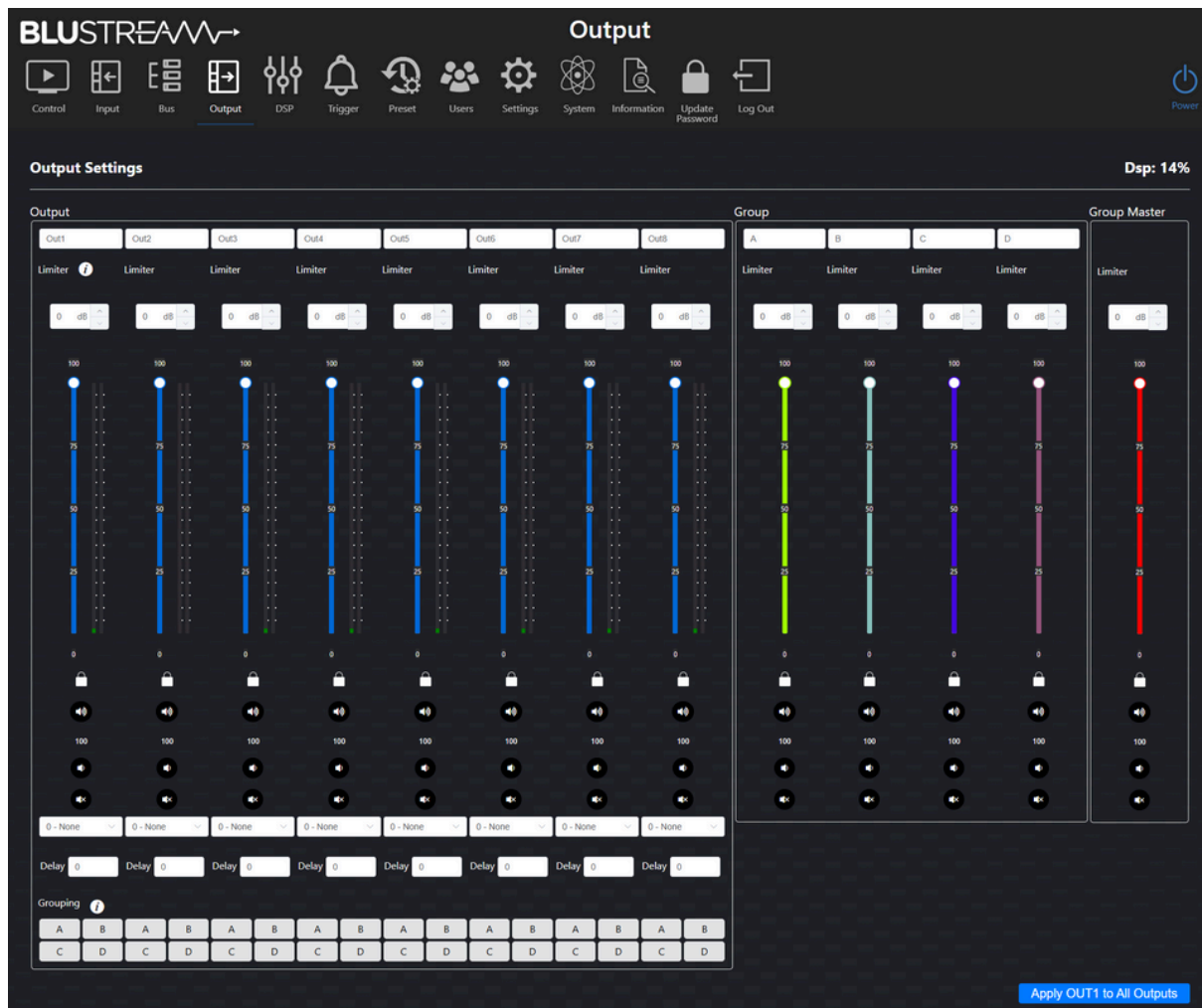

**Output Settings** (mixer control instructions can be found on page 08):

### Naming

- To set a name for an output, type a new name into the desired label for the corresponding output.

### Limiter

- All output and group channels feature a limiter in which a virtual maximum audio limit can be set to prevent the output from going over a certain threshold. At 0dB, the output signal level will match the input signal level

This limit is scaled to the output slider, where the limit will become 100% of the channel slider.

Please note: The values on the channel slider will remain the same when the limiter is active. Users on the control page will not see that the limiter is active.

## Output Settings (continued)

### Mono and Stereo Control

Each output channel can operate in either a mono or stereo mode. These can be selected from the drop down menu:

Mode 0	None The Left channel output plays from the Left channel input, the Right channel output plays from the Right channel input
Mode 1	Swap Left and Right audio channels The Left channel output plays from the Right channel input, the Right channel output plays from the Left channel input
Mode 2	Mono Left and Right The Left and Right channel output both play the combined signal from the Left and Right channel input
Mode 3	Mono All Left The Left and Right channel output both play the same signal from the Left channel input
Mode 4	Mono All Right The Left and Right channel output both play the same signal from the Right channel input
Mode 5	Mono Left - Right The Left and Right channel output both play the same signal from the Left channel input minus the signal from the Right channel input
Mode 6	Mono Right - Left The Left and Right channel output both play the same signal from the Right channel input minus the signal from the Left channel input

### Delay

A delay can set by entering a value (in milliseconds) in the Delay field. This can be used to rectify lip sync and other similar issues.

### Grouping

The grouping feature allows you to combine audio output channels resulting in a single volume and source control to multiple outputs. Up to four groups can be used simultaneously. Press the A, B, C or D button to assign an output channel to a group.

Control for the limiter, volume and stereo control, muting, and renaming of the group can be configured in the group section.

# Web-GUI - DSP

The DMP168 features an in-built DSP with a parametric EQ. All input channels and output channels can access the DSP. Individual L&R control can be enabled by pressing the corresponding lock/unlock button.

The screenshot displays the DSP configuration interface for the BLUSTREAM DMP168. At the top, a navigation bar includes icons for Control, Input, Bus, Output, DSP (active), Trigger, Preset, Users, Settings, System, Information, Update Password, and Log Out. A power icon is located in the top right corner.

**DSP Input Settings** (Dsp: 14%)

Inputs In1 through In16 are shown with lock/unlock buttons. A frequency response graph plots Gain [dB] from -24dB to 24dB against Frequency [Hz] on a logarithmic scale from 20Hz to 20KHz. Eight control points are marked on the graph. Below the graph, settings for each point are listed:

Point	Filter Type	Freq [Hz]	Slope [dB]	Gain [dB]	Q
1	High Pass	20	0 (off)	0.0	3.00
2	Low Shelf	250	0.0	0.0	3.00
3	Parametric	500	0.0	0.0	3.00
4	Parametric	1000	0.0	0.0	3.00
5	Parametric	2000	0.0	0.0	3.00
6	Parametric	3000	0.0	0.0	3.00
7	High Shelf	4000	0.0	0.0	3.00
8	Low Pass	20000	0 (off)	0.0	3.00

Buttons: Apply to All Inputs, Reset Selected Input, Reset All Inputs

**DSP Output Settings**

Outputs Out1 through Out8 are shown with lock/unlock buttons. The same frequency response graph and control settings are displayed for the outputs.

Buttons: Apply to All Outputs, Reset Selected Output, Reset All Outputs

## DSP Input/Output Settings:

To modify a channel's DSP settings, select the desired channel from the list. The following controls can then be modified:

### High Pass Filter

- A High Pass Filter removes low frequencies while allowing high frequencies to pass through.

Setting the 'Freq' will attenuate all frequencies below the set frequency.

The slope determines the rate of attenuation, measured in decibels (dB) per octave. Setting this to zero will disable the High Pass Filter. Drastic attenuation over a small range of frequencies, or gradual attenuation over a larger range of frequencies, can be achieved by adjusting the slope.

### Low Shelf

- A Low Shelf represents a flat raise or drop of all frequencies below the 'Freq' value. This leaves the frequencies above this spot untouched by the Low Shelf.

### PEQ Band 1-4

- Each parametric EQ (PEQ) allows you to make a cut or a boost to a band on the frequency spectrum. 'Freq' will set the centre frequency on the band which will be the centre of the bell shaped boost or cut.

Gain will set the amount of boost or cut being applied.

Q refers to how narrow or wide the boost or cut is. The higher the Q value, the narrower the bandwidth will be. Similarly, the lower the Q value, the wider the bandwidth will be.

A visual example showing the effect the Q value has on the shape of the curve is shown below.

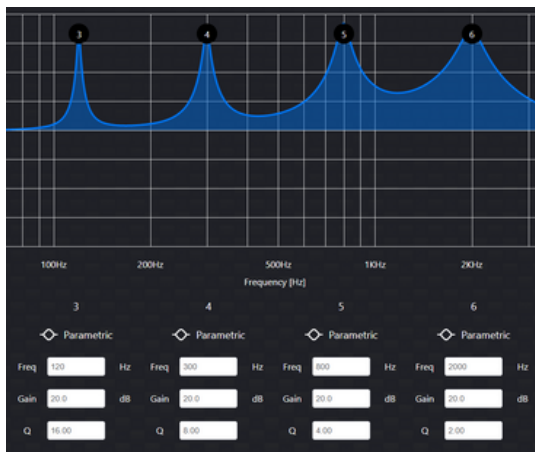

### High Shelf

- A High Shelf represents a flat raise or drop of all frequencies above the 'Freq' value. This leaves the frequencies below this spot untouched by the High Shelf.

### Low Pass Filter

- A Low Pass Filter removes high frequencies while allowing low frequencies to pass through.

Setting the 'Freq' will attenuate all frequencies above the set frequency.

The slope determines the rate of attenuation, measured in decibels (dB) per octave. Setting this to zero will disable the Low Pass Filter. Drastic attenuation over a small range of frequencies, or gradual attenuation over a larger range of frequencies, can be achieved by adjusting the slope.

To quickly apply a DSP configuration to all input/output channels, set up the desired DSP configuration then press the corresponding 'Apply to All Inputs/Outputs' button. This will apply the currently selected DSP configuration to all input/output channels.

To reset the currently selected DSP configuration, press the 'Reset Selected Input/Output' button.

To reset all DSP configurations, press the 'Reset All Inputs/Outputs' button.

**Usage:** Using the DSP, it's possible to configure many different setups, e.g., a subwoofer channel by changing the Audio Mode from the Output page and using the Low Shelf to EQ the signal.

## Web-GUI - Trigger

The DMP168 includes a 4 x 2 pin Phoenix connector relays, which can be used to trigger functions such as recalling presets, ducking and muting. The relays can be controlled by connecting them to an external control device, and setting up the control logic in the web-GUI

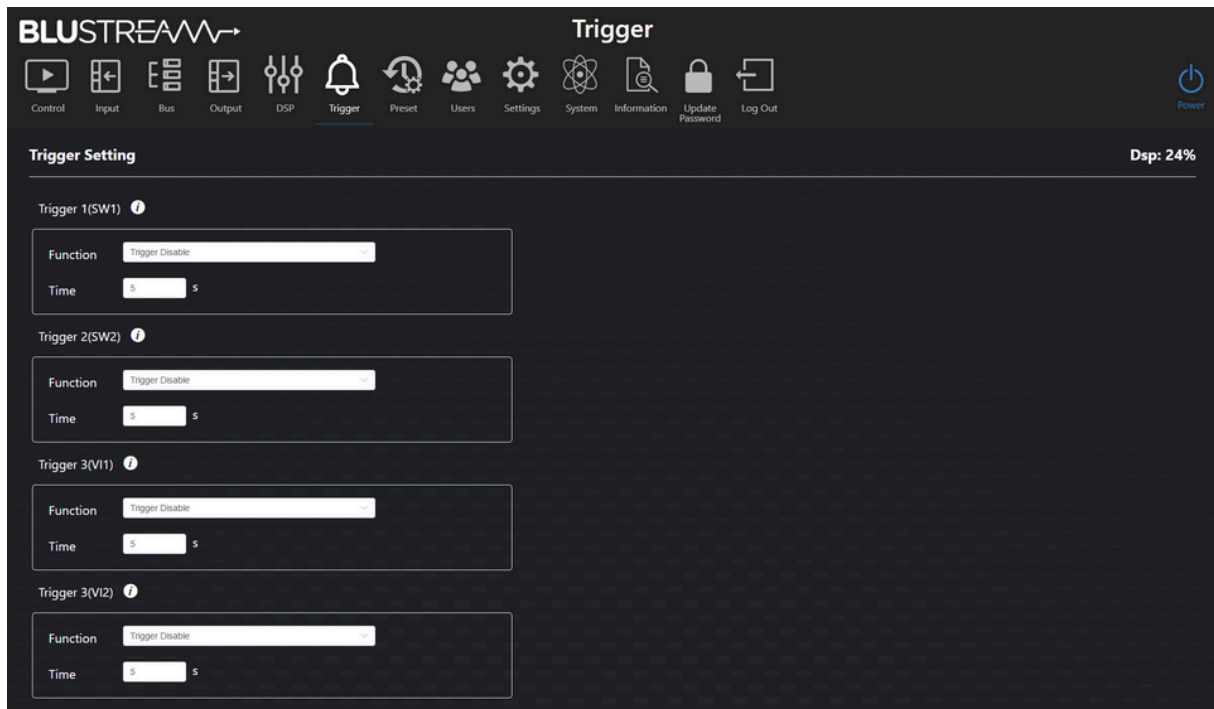

There are 2 x Switch Mode relays and 2 x Voltage mode relays:

Switch Mode relays

- Short the pins and the set function will be triggered

Voltage Mode relays

- When a high signal (2-15V AC/DC) is detected, the set function will be triggered.

The following functions can be set to trigger:

Recall Preset

- When triggered, the selected preset will be loaded

Recall Ducker

- When triggered, the selected bus channel will be loaded into the ducker

System Mute

- When triggered, the system will be muted

Channel Mute

- When triggered, the selected output channel will be muted

Time

Set the time it will take for the function to activate after the relay has been triggered.

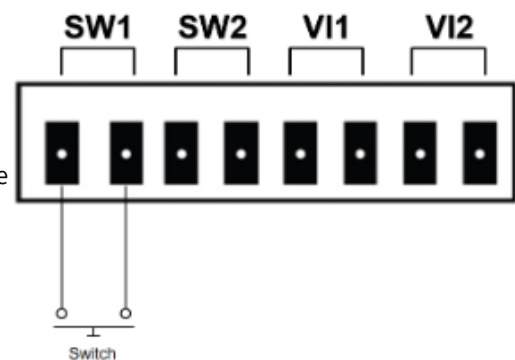

# Web-GUI - Preset

Once the DMP168 has been set up, the current configuration can be saved to a preset. If multiple presets are saved, they can be quickly switched between.

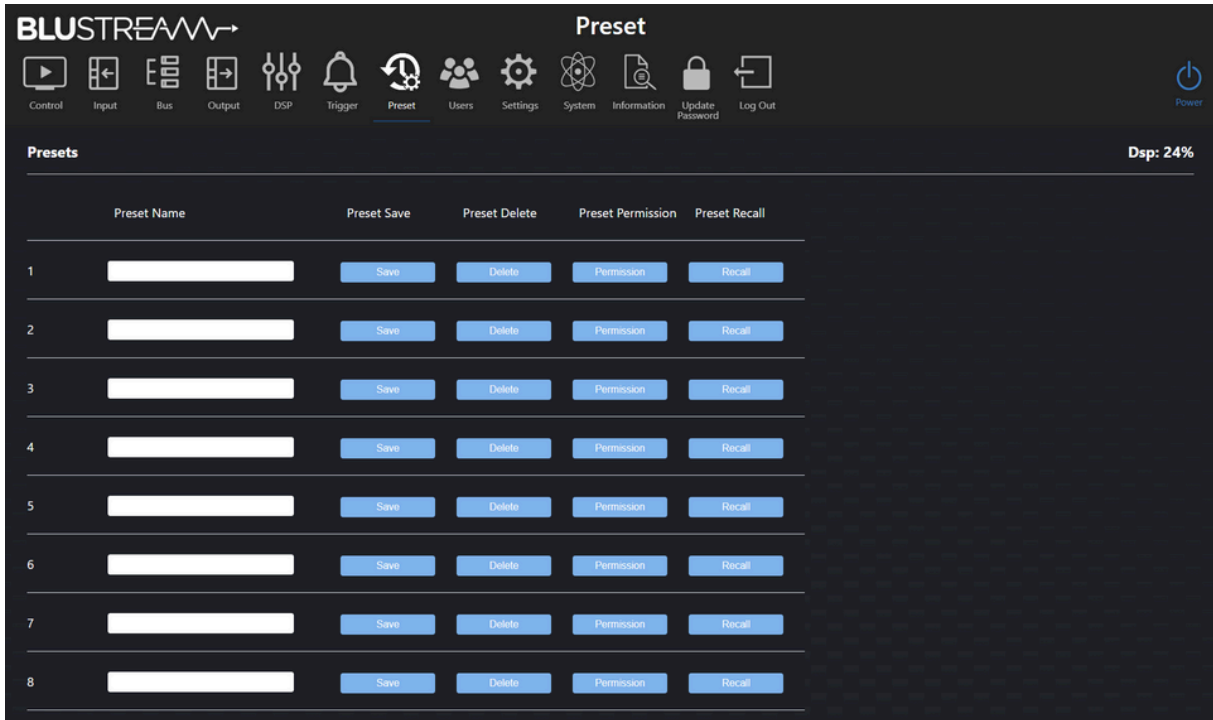

**Save**

- To save the current configuration to a preset, enter a name into the Preset Name field and press the Save button.

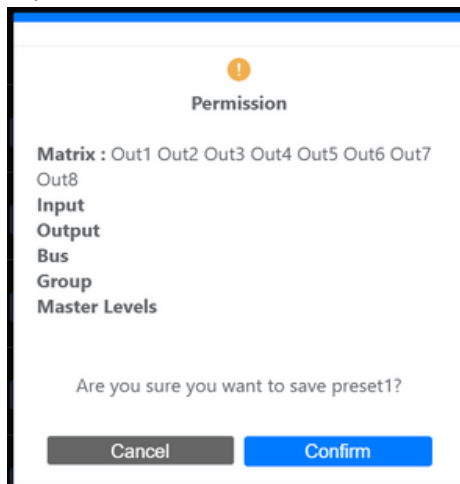

The preset can now be recalled from the Control page, by triggering a relay, through the API or via the Preset web-GUI page.

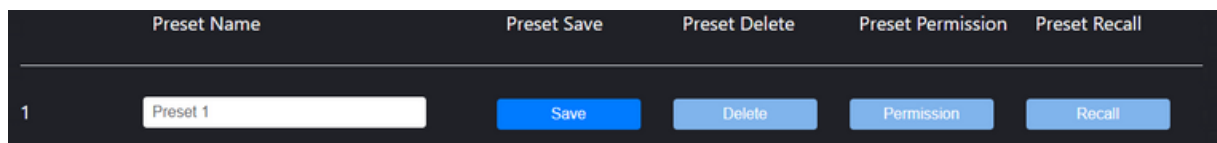

**Delete**

- To delete a preset, press the Delete button and press Confirm in the dialog box.

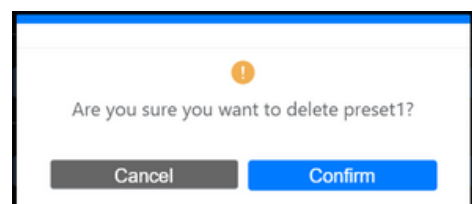

Permission

- The preset can be configured to only recall settings that have been given permission. Press the Permissions button in order to modify the permissions for that preset in a sub menu.

Select which items the preset will be able to modify. For example: by unchecking Input and Output, these can be set independently of the preset. When the preset is recalled, the Input and Output settings will not be overridden.

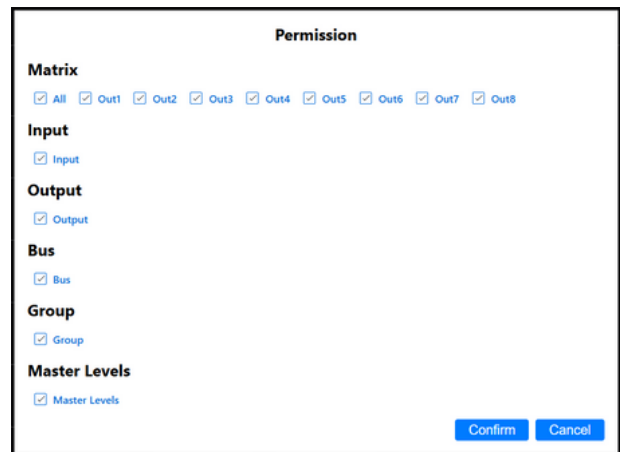

Recall

- The Recall button will recall the corresponding preset.

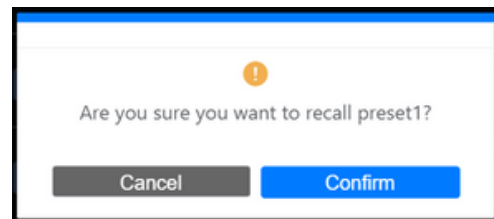

## Web-GUI - Users

The DMP168 can be set up with different levels of access to the web-GUI per user. Access can be restricted based on which pages will have access to, what channels the users can see and configure, and what presets the user can select.

Please note: A separate user should be set up and used after installation of the unit in order to prevent non-administrator users from changing settings and potentially damaging connected equipment.

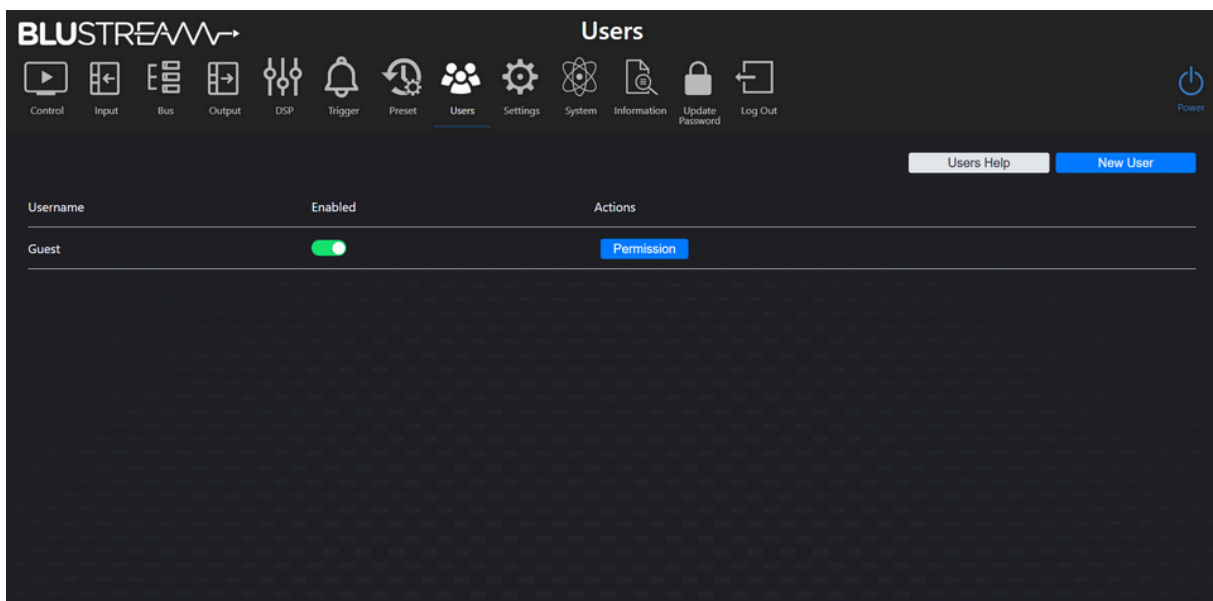

**Web-GUI Users (continued)**

To create a new user, press the New User button. Set a username and password and press Create.

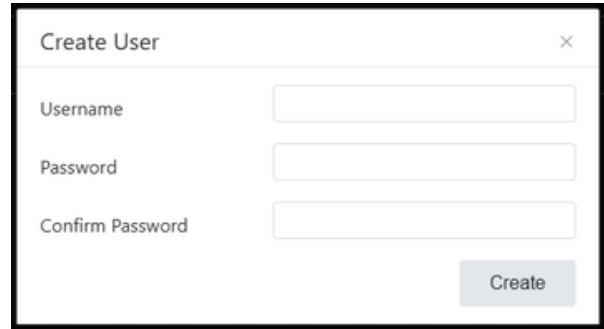

The image shows a 'Create User' dialog box with a close button (X) in the top right corner. It contains three input fields: 'Username', 'Password', and 'Confirm Password'. A 'Create' button is located at the bottom right of the dialog.

The new user will appear in the list.

Username	Enabled	Actions
Guest	<input checked="" type="checkbox"/>	<a href="#">Permission</a>
User 1	<input checked="" type="checkbox"/>	<a href="#">Permission</a> <a href="#">Delete</a> <a href="#">Update Password</a>

Press the Permissions button in order to modify the permissions for that user in a sub menu.

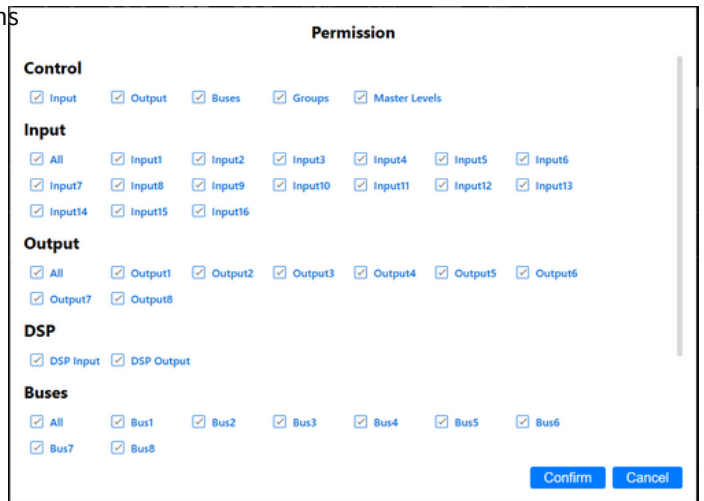

The image shows a 'Permission' configuration window. It has several sections with checkboxes: 'Control' (Input, Output, Buses, Groups, Master Levels), 'Input' (All, Input1-16), 'Output' (All, Output1-8), 'DSP' (DSP Input, DSP Output), and 'Buses' (All, Bus1-8). 'Confirm' and 'Cancel' buttons are at the bottom right.

To enable / disable a user, press the respective toggle.

To delete a user, press the respective Delete button.

To change the password for a user, press the respective Update Password button

Please note: Admin (blustream) and Guest user cannot be deleted. The guest user should either have permissions set or be disabled to prevent unwanted access, as they do not require credentials for control of the unit.

## Web-GUI - Settings

Network settings for the DMP168 can be configured from this page, such as: IP settings, Telnet and mDNS.

The default network settings can be restored by pressing the Set Network Defaults button.

To save the current network configuration, press the Save button.

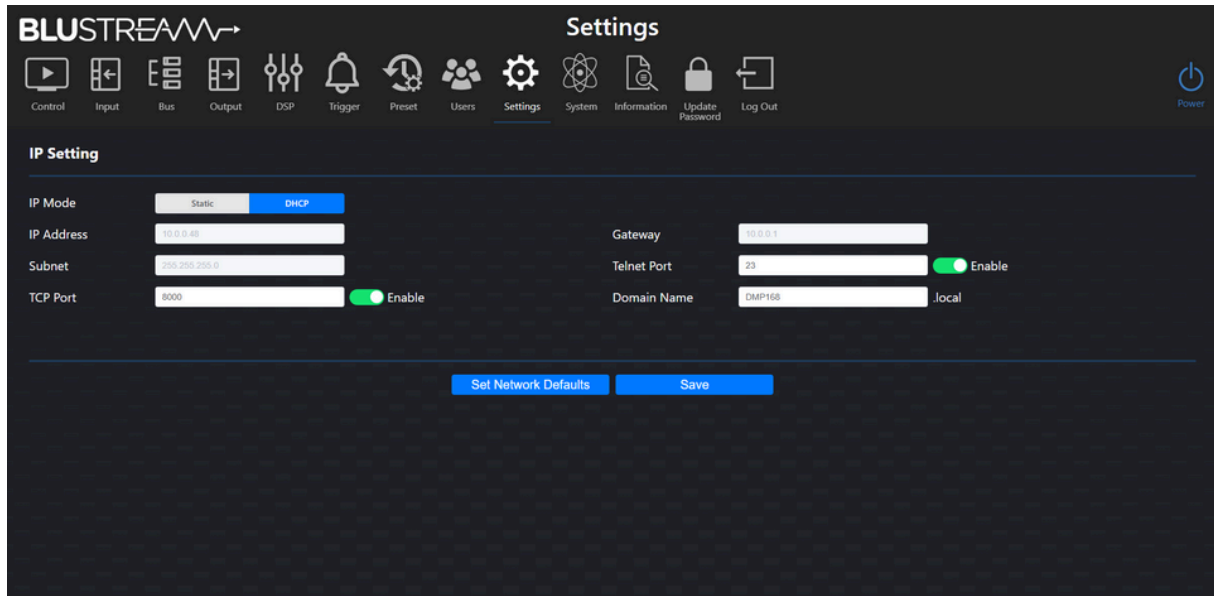

### IP Settings:

- IP Mode
  - Static / DHCP
- IP Address
  - Disabled when in DHCP mode
- IP Subnet
  - Disabled when in DHCP mode
- TCP Port
  - Enable / Disable (default: 8000)
- Gateway
  - Disabled when in DHCP mode
- Telnet Port
  - Enable / Disable (default: 23)
- Domain name (mDNS)
  - mDNS is a protocol used in network environments to resolve hostnames to IP addresses within local networks without the need for a dedicated DNS server. The DMP168 is able to be accessed via the hostname if the IP address is not known. By default this is set to dmp168.local

# Web-GUI - System

The System page allows for configuration of the DMP168, enabling and disabling features, as well as firmware upgrading and factory resetting.

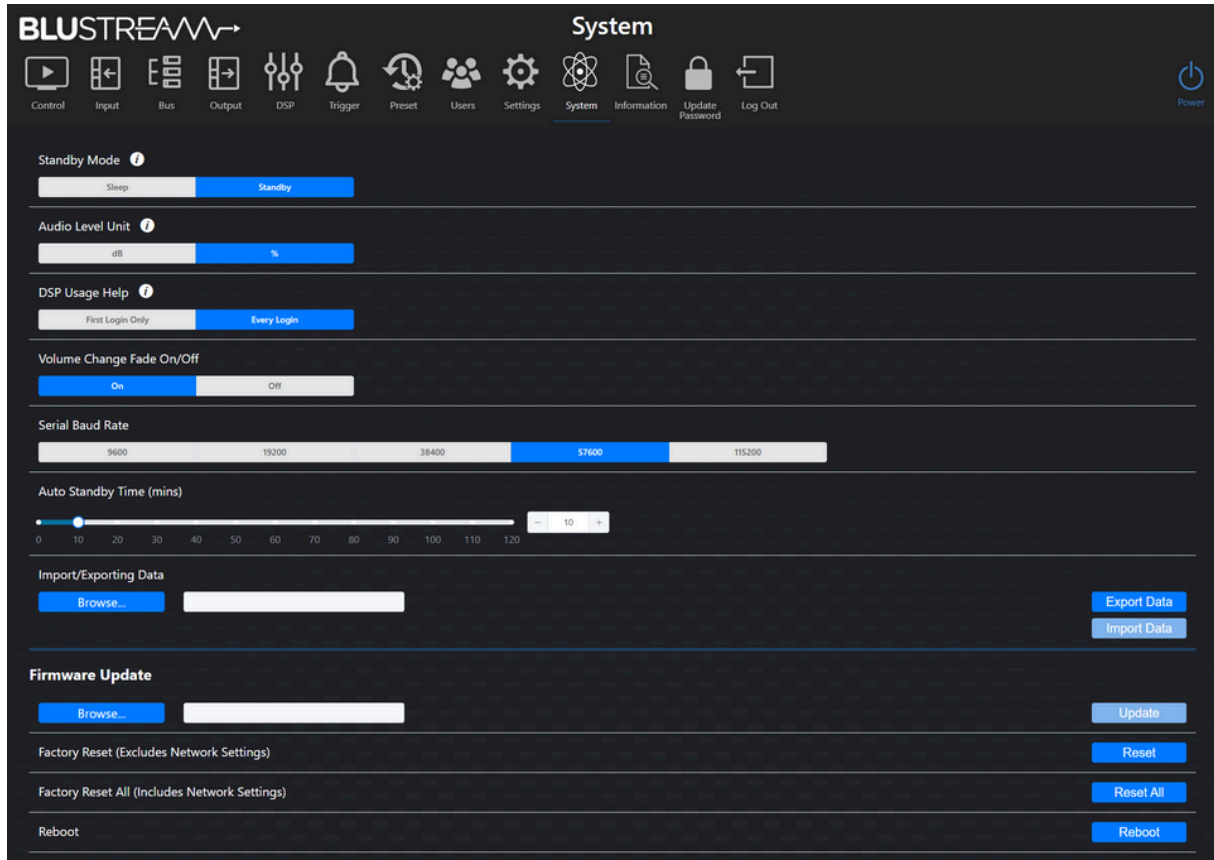

## Standby Mode

The unit will enter standby mode once the Auto Standby Time has elapsed. There are two standby modes that can be selected:

- Sleep                      the unit will power off but the API and web-GUI remain active
- Standby                    the DSP board remains powered allowing the signal sensing feature to power on the unit

## Audio Level Unit

- dB                            the audio level on the web-GUI will be measured in decibels
- %                            the audio level on the web-GUI will be measured in a percentage

## DSP Usage Help

The DSP usage help pop-up can be displayed only at first login or at each login; the pop-up shows usage percentage of the internal processor based on each feature activated.

- First Login Only        the pop-up will be shown upon a user logging in for the first time
- Every Login             the pop-up will be shown every time a user logs in

## Volume Change Fade On/Off

- ON/OFF                    volume changes will transition smoothly between levels when enabled

## Serial Baud Rate

Select the Baud Rate for the RS-232 Serial port

9600/19200/38400/57600/115200

## Web-GUI - System (continued)

### Auto Standby Time (mins)

Use the slider to set the interval of inactivity until the unit enters standby mode

### Import/Exporting Data

Allows for the configuration settings to be imported into the system or exported to a file. This can be used when backing up a unit that has been configured, or when setting up a new unit that need to be configured.

### Firmware Update

Browse your device for a firmware file to upload to the unit.

### Factory Reset (Excludes Network Settings)

Erases all settings, expect for network settings, and reboots the unit.

### Factory Reset All (Includes Network Settings)

Erases all settings and reboots the unit.

### Reboot

Reboots the unit.

## Web-GUI - Information

The Information page displays the model name, serial number, web-GUI firmware version and MCU firmware version of the DMP168. It also displays network configuration, temperature and uptime data.



Status	
Model	DMP168
MCU Version	V1.0.1q
GUI Version	V1.0.2k
DSP Version	V1.5.7
Domain Name	DMP168
IP Address	10.0.0.48
Subnet Mask	255.255.255.0
Gateway	10.0.0.1
MAC Address	34:D0:B8:27:2D:96
Temperature	44.5°C
Uptime	0000:00:46:59

## Specifications

- **Audio Input Connectors:** 8 x Analogue RCA (Left / Right), 4 x Optical (S/PDIF), 4 x Digital RCA (S/PDIF)
- **Audio Output Connectors:** 8 x Analogue RCA (Left / Right)
- **RS-232 serial port:** 1 x 3-Pin Phoenix connector
- **TCP/IP Control:** 1 x RJ45, female
- **Control port:** 4 x 2-Pin Phoenix connector
- **Rack-Mountable:** 1U rack height, rack ears included
- **Casing Dimensions (W x D x H):** 440mm x 226mm x 44mm
- **Dimensions Including Connections & Feet (W x D x H):** 440mm x 235mm x 51mm
- **Shipping Weight:** xxkg TBC
- **Operating Temperature:** 32°F to 104°F (0°C to 40°C)
- **Storage Temperature:** -4°F to 140°F (-20°C to 60°C)
- **Power Supply:** Internal 100-240V AC

NOTE: Specifications are subject to change without notice. Weights and dimensions are approximate.

---

## Package Contents

- 1 x DMP168
  - 1 x IR receiver
  - 1 x 19" Rack Mounting kit
  - 4 x Mounting feet
  - 1 x Quick Reference Card
  - 1 x IEC Power Cable
- 

## Maintenance

Clean this unit with a soft, dry cloth. Never use alcohol, paint thinner or benzene to clean this unit.

BLUSTREAM

Example Schematic  
DMP168

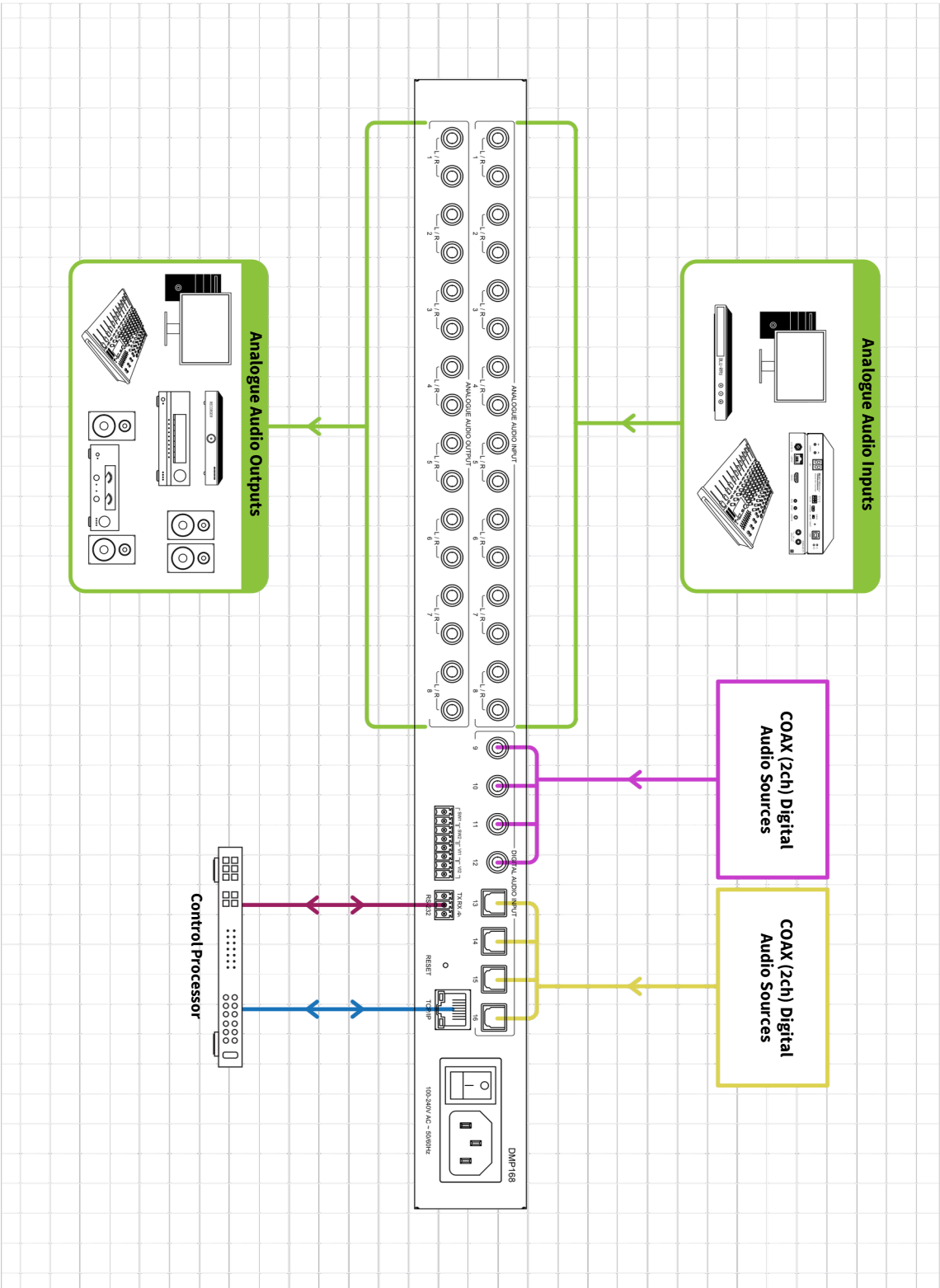
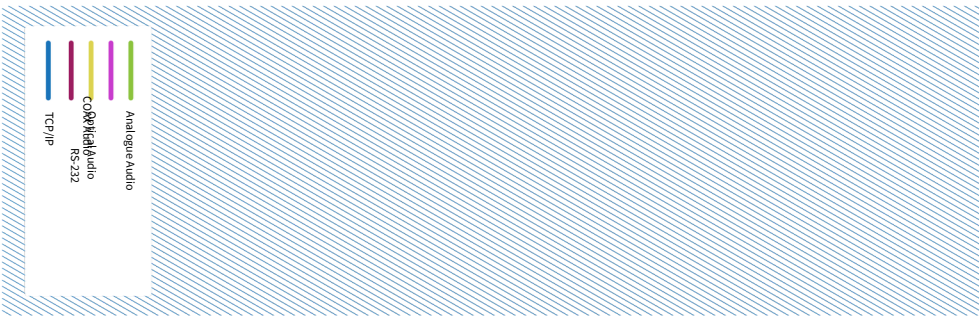

# RS-232 Configuration and Telnet Commands

The DMP168 can be controlled via serial and TCP/IP.

The default RS-232 communication settings are:

Baud rate:  
57600 Data bits:  
8 Stop bits: 1  
Parity bit: none

The following pages list all available serial / IP commands.

## Commonly Used Serial Commands

There are several commands that are commonly used for control and testing:

STATUS Status will give feedback on the switcher such as outputs on, type of connection, etc.

PON Power on Power off Toggling the main output

POFF ON or OFF as required

OUTON/OFF

Example: OUTON (This would turn the main output on)

OUT FRyy (yy is the input)

Example: OUT FR04 (This would switch the main output to source input 4)

## Common Mistakes

- Carriage return: Some programs do not require the carriage return where as other will not work unless sent directly after the string. In the case of some Terminal software the token <CR> is used to execute a carriage return. Depending on the program you are using this token maybe different. Some other examples that other control systems deploy include \r or 0D (in hex)
- Spaces: Blustream commands do not require space between commands unless specified. There may be some programs that require spacing in order to work.
  - How the string should look is as follows: OUTON
  - How the string may look if spaces are required: OUT{Space}ON
- Baud rate or other serial protocol settings not correct

RS-232 Configuration and Telnet Commands (continued)

COMMAND	ACTION
?/HELP	Print Help Information
STATUS	Print System Status And Port Status
UPTIME TEMP	Print System Uptime
PON POFF	Print System Temperature
STANDBY xx	Power On, System Run On Normal State Power Off, System Run On Power Save State
	Set System Standby Mode To xx xx=0:Sleep, 1:Stanndby
RESET	Reset System Settings To Default (Should Type "Yes" To Confirm, "No" To Discard)
RESET ALL	Reset System And Network Settings To Default (Should Type "Yes" To Confirm, "No" To Discard)
REBOOT	Set System Key Control On Or Off
	Set System Auto Standby Time
AUTO STB xx	xx=0: Auto Standby Off xx=[1...120]: Auto Standby Time,(mins)
RSB xx	Set RS232 Baud Rate To xx Bps xx=[0:115200, 1:57600, 2:38400, 3:19200, 4:9600]
LEVEL UNIT xx	Set Audio Level Unit To xx xx=[0...1]: 0=dB, 1=%
DSP STATUS	The Proportion Of Resources Currently Used By DSP
VOLUME CHANGE FADE ON/OFF	Set Volume Change Fade On Or Off
IN xx CH LOCK ON/OFF	Set Input: xx L/R Channels Lock/Unlock xx=[0...16]: 0: All
IN xx GAIN vv yy zz	Set Input: xx Gain To yy xx=[0...16]: 0: All vv=[L, R or LR] This Is Optional. If L Or R Is Not Specified Then Both Channels Are Adjusted yy=[0...100]: Gain Value yy=[-76...+24] When zz = dB (Step=0.01) yy= + Or - To Increment Or Decrement The Gain If zz == dB Then The Audio Format Is In dB, If Any Other Characters (Or No Characters) Are Entered Then The Gain Is In %
IN xx MUTE vv ON/OFF	Set Input: xx Mute On Or Off xx=[0...16]: 0: All vv=[L, R or LR] This Is Optional. If L Or R Is Not Specified Then Both Channels Are Adjusted
IN xx APPLY TO ALL	Set Input: xx Mute/Gain Apply TO All Inputs xx=1
IN xx EQ LOCK ON/OFF	Set Input: xx EQ L/R Lock/Unlock xx=[0...16]: 0: All
IN xx EQ vv yy FRQ zz SLOPE aa	Set Input: xx EQ yy To FRQ zz SLOPE aa xx=[0...16]: 0: All vv=[L, R or LR] This Is Optional. If L Or R Is Not Specified Then Both Channels Are Adjusted yy=1/8: EQ Index zz=[20...20000]: Frequency Value [Hz] aa=[0,6,12,18 or 24]: Slope Value [dB], 0:Off

COMMAND	ACTION
IN xx EQ vv yy FRQ zz GAIN aa	Set Input: xx EQ yy To FRQ zz GAIN aa xx=[0...16]: 0: All vv=[L, R or LR] This Is Optional. If L Or R Is Not Specified Then Both Channels Are Adjusted yy=2/7: EQ Index zz=[20...20000]: Frequency Value [Hz] aa=[-20...+20]: Gain Value [dB] (Step=0.1)
IN xx EQ vv yy FRQ zz GAIN aa Q bb	Set Input: xx EQ yy To FRQ zz GAIN aa Q bb xx=[0...16]: 0: All vv=[L, R or LR] This Is Optional. If L Or R Is Not Specified Then Both Channels Are Adjusted yy=[3...6]: EQ Index zz=[20...20000]: Frequency Value [Hz] aa=[-20...+20]: Gain Value [dB] (Step=0.1) bb=[0.02...50]: Q Value(Step=0.01)
IN xx EQ vv yy RESET	Reset Input: xx EQ To Default Setting xx=[0...16]: 0: All vv=[L, R or LR] This Is Optional. If L Or R Is Not Specified Then Both Channels Are Adjusted yy=[0...8]: EQ Index 0: All
IN xx vv TO BUS yy zz	Put Input: xx Into BUS: yy x x=[1...16] vv=[L, R or LR] This Is Optional. If L Or R Is Not Specified Then Both Channels Are Adjusted yy=[1...8]: BUS Index zz=[L, R or LR] This Is Optional. If L Or R Is Not Specified Then Both Channels Are Adjusted
BUS xx vv REM IN yy zz	Set BUS: xx Remove Input: yy x x=[1... 8] vv=[L, R or LR] This Is Optional. If L Or R Is Not Specified Then Both Channels Are Adjusted y y=[1...16] zz=[L, R or LR] This Is Optional. If L Or R Is Not Specified Then Both Channels Are Adjusted
BUS xx CH LOCK ON/OFF	Set BUS: xx L/R Channels Lock/Unlock xx=[0...8]: 0: All
BUS xx GAIN vv yy zz	Set BUS: xx Gain To yy xx=[0...8]: 0: All vv=[L, R or LR] This Is Optional. If L Or R Is Not Specified Then Both Channels Are Adjusted yy=[0...100]: Gain Value yy=[-76...+24] When zz = dB (Step=0.01) yy= + Or - To Increment Or Decrement The Gain If zz == dB Then The Audio Format Is In dB, If Any Other Characters (Or No Characters) Are Entered Then The Gain Is In %
BUS xx MUTE zz ON/OFF	Set BUS: xx Mute On Or Off xx=[0...8]: 0: All zz=[L, R or LR] This Is Optional. If L Or R Is Not Specified Then Both Channels Are Adjusted
BUS xx APPLY TO ALL	Set BUS: xx Mute/Gain Apply To All BUS xx=1

RS-232 Configuration and Telnet Commands (continued)

COMMAND	ACTION	COMMAND	ACTION
BUS MASTER GAIN vv xx yy	Set BUS Master Gain Value  vv=[L, R or LR] This Is Optional. If L Or R Is Not Specified Then Both Channels Are Adjusted xx=[0...100]: Gain Value xx=[-76...+24] When yy = dB (Step=0.01) xx= + Or - To Increment Or Decrement The Gain If yy == dB Then The Audio Format Is In dB, If Any Other Characters (Or No Characters) Are Entered Then The Gain Is BUS %	OUT xx VOL vv yy zz	Set Output: xx Volume To yy  xx=[0...8]: 0: All vv=[L, R or LR] This Is Optional. If L Or R Is Not Specified Then Both Channels Are Adjusted yy=[0...100]: Volume Value yy=[-76...+24] When zz = dB (Step=0.01) yy= + Or - To Increment Or Decrement The Volume If zz == dB Then The Audio Format Is In dB, If Any Other Characters (Or No Characters) Are Entered Then The Volume Is In %
BUS MASTER MUTE vv ON/OFF	Set BUS Master Mute On Or Off vv=[L, R or LR] This Is Optional. If L Or R Is Not Specified Then Both Channels Are Adjusted	OUT xx MUTE vv ON/ OFF	Set Output: xx Mute On Or Off xx=[0...8]: 0: All vv=[L, R or LR] This Is Optional. If L Or R Is Not Specified Then Both Channels Are Adjusted
BUS MASTER CH LOCK ON/OFF	Set BUS Master L/R Channels Lock/Unlock	OUT xx DELAY vv yy	Set Output: xx Delay Time To yy (ms) xx=[0...8]: 0: All vv=[L, R or LR] This Is Optional. If L Or R Is Not Specified Then Both Channels Are Adjusted yy=[0...500]: Delay Time, Millisecond
BUS xx DUCK vv SOURCE yy zz	Set BUS: xx Duck Source To yy x x =[1... 8] vv=[L, R or LR] This Is Optional. If L Or R Is Not Specified Then Both Channels Are Adjusted yy=[0...16]: 0: Off zz=[L, R or LR] This Is Optional. If L Or R Is Not Specified Then Both Channels Are Adjusted	OUT xx MIX yy	Set Output: xx Mix yy xx=[0...8]: 0: All yy=0: None yy=1: Swap (Left And Right) yy=2: Mono (Left + Right) yy=3: Mono (All Left) yy=4: Mono (All Right) yy=5: Mono (Left - Right) yy=6: Mono (Right - Left)
BUS xx DUCK zz SENS yy	Set BUS: xx Duck Sensitivity To yy (dBfs) x x =[1... 8] zz=[L, R or LR] This Is Optional. If L Or R Is Not Specified Then Both Channels Are Adjusted yy=[-60...0]	OUT xx APPLY TO ALL	Set Output: xx Mute/Gain/Delay Apply To All Outputs xx=1
BUS xx DUCK zz LEVEL yy	Set BUS: xx Duck Level To yy x x =[1... 8] zz=[L, R or LR] This Is Optional. If L Or R Is Not Specified Then Both Channels Are Adjusted y y =[0...10 0]	OUT xx EQ LOCK ON/ OFF	Set Output: xx EQ L/R Lock/Unlock xx=[0...8]: 0 : All
BUS xx DUCK zz TIME yy	Set BUS: xx Duck Time To yy(ms) x x =[1... 8] zz=[L, R or LR] This Is Optional. If L Or R Is Not Specified Then Both Channels Are Adjusted yy=[0...10000]Duck Time, Millisecond	OUT xx EQ yy vv FRQ zz SLOPE aa	Set Output: xx EQ yy To FRQ zz SLOPE aa xx=[0...8]: 0: All vv=[L, R or LR] This Is Optional. If L Or R Is Not Specified Then Both Channels Are Adjusted yy=1/8: EQ Index zz=[20...20000]: Frequency Value [Hz] aa=[0,6,12,18 or 24]: Slope Value [dB], 0:Off
OUT xx vv FR yy zz	Set Output: xx From Input: yy xx=[0...8]: 0: All vv=[L, R or LR] This Is Optional. If L Or R Is Not Specified Then Both Channels Are Adjusted y y =[1... 24]	OUT xx EQ vv yy FRQ zz GAIN aa	Set Output: xx EQ yy To FRQ zz GAIN aa xx=[0...8]:0: All vv=[L, R or LR] This Is Optional. If L Or R Is Not Specified Then Both Channels Are Adjusted yy=2/7: EQ Index zz=[20...20000]: Frequency Value [Hz] aa=[-20...+20]: Gain Value [dB] (Step=0.1)
OUT xx vv REM yy zz	Set Output: xx Remove Input: yy xx=[0...8]: 0: All vv=[L, R or LR] This Is Optional. If L Or R Is Not Specified Then Both Channels Are Adjusted y y =[1... 24] zz=[L, R or LR] This Is Optional. If L Or R Is Not Specified Then Both Channels Are Adjusted	OUT xx EQ yy vv FRQ zz GAIN aa Q bb	Set Output: xx EQ yy To FRQ zz GAIN aa Q bb xx=[0...8]: 0: All vv=[L, R or LR] This Is Optional. If L Or R Is Not Specified Then Both Channels Are Adjusted yy=[3...6]: EQ Index zz=[20...20000]: Frequency Value [Hz] aa=[-20...+20]: Gain Value [dB] (Step=0.1) bb=[0.02...50]: Q Value(Step=0.01)
OUT xx CH LOCK ON/ OFF	Set Output: xx L/R Channels Lock/Unlock xx=[0...8]: 0: All		

RS-232 Configuration and Telnet Commands (continued)

COMMAND	ACTION
OUT xx EQ vv yy RESET	Set Output: xx EQ yy To FRQ zz GAIN aa Q bb  xx=[0..8]: 0: All vv=[L, R or LR] This Is Optional. If L Or R Is Not Specified Then Both Channels Are Adjusted yy=[3..6]: EQ Index zz=[20..20000]: Frequency Value [Hz] aa=[-20..+20]: Gain Value [dB] (Step=0.1) bb=[0.02..50]: Q Value(Step=0.01)
OUT xx GROUP yy	Set Output: xx To Group yy xx=[0..8]: 0: All yy=[0..4]: 0: Remove From Group
OUT xx MAX VOL vv yy	Set Users Should Be Able To Set Output: xx The Maximum Volume yy xx=[0..8]: 0: All vv=[L, R or LR] This Is Optional. If L Or R Is Not Specified Then Both Channels Are Adjusted yy=[0..24]: dB
GROUP xx CH LOCK ON/OFF	Set Group: xx L/R Channels Lock/Unlock xx=[0..4]: 0: All
GROUP xx VOL vv yy zz	Set Group: xx Volume To yy xx=[0..4]: 0: All vv=[L, R or LR] This Is Optional. If L Or R Is Not Specified Then Both Channels Are Adjusted yy=[0..100]: Volume Value yy=[-76..+24] When yy = dB (Step=0.01) yy= + Or - To Increment Or Decrement The Volume  If zz == dB Then The Audio Format Is In dB, If Any Other Characters (Or No Characters) Are Entered Then The Volume Is In %
GROUP xx MUTE vv ON/OFF	Set Group: xx Mute On Or Off xx=[0..4]: 0: All vv=[L, R or LR] This Is Optional. If L Or R Is Not Specified Then Both Channels Are Adjusted
OUT MASTER VOL vv xx yy	Set Output Master Volume Value vv=[L, R or LR] This Is Optional. If L Or R Is Not Specified Then Both Channels Are Adjusted xx=[0..100]: Volume Value xx=[-76..+24] When yy = dB (Step=0.01) xx= + Or - To Increment Or Decrement The Volume  If yy == dB Then The Audio Format Is In dB, If Any Other Characters (Or No Characters) Are Entered Then The Volume Is In %
OUT MASTER MUTE vv ON/OFF	Set Output Master Mute On Or Off vv=[L, R or LR] This Is Optional. If L Or R Is Not Specified Then Both Channels Are Adjusted
OUT MASTER CH LOCK O N/O F	Set Output Master L/R Channels Lock/Unlock
GROUP xx MAX VOL vv yy	Set Users Should Be Able To Set Group: xx The Maximum Volume yy xx=0..4]: 0: All vv=[L, R or LR] This Is Optional. If L Or R Is Not Specified Then Both Channels Are Adjusted yy=[0..24]: dB

COMMAND	ACTION
OUT MASTER MAX VOL vv yy	Set Users Should Be Able To Set Output Master The Maximum Volume yy  vv=[L, R or LR] This Is Optional. If L Or R Is Not Specified Then Both Channels Are Adjusted yy=[0..24]: dB
PRESET xx STATUS	Print Preset xx Config Status xx=[1..8]: Select Preset Index
PRESET xx SAVE	Save Current Config To Preset: xx xx=[1..8]: Select Preset Index
PRESET xx APPLY	Recall Preset: xx Config To The Current Setting xx=[1..8]: Select Preset Index
PRESET xx DELETE	Delete Preset: xx From The System xx=[1..8]: Select Preset Index
TRG xx FUNC yy TYPE vv zz	Set Trigger:xx Function To yy With Type vv zz xx=[0..4]: 0: All y y =[0..4] yy=0:Trigger Disable yy=1:Recall Preset: zz=[1..8]: Select Preset Index yy=2:Recall Duker: zz=[1..8]: Bus Index vv=[L, R or LR] This Is Optional. If L Or R Is Not Specified Then Both Channels Are Adjusted yy=3:System Mute yy=4:Channel Mute: zz=[1..8]: Select Output Channel Mute vv=[L, R or LR] This Is Optional. If L Or R Is Not Specified Then Both Channels Are Adjusted
TRG xx TIME yy	Set Trigger: xx Effective Time To yy xx=[0..4]: 0: All yy=[0..120] Seconds
NET DHCP ON/OFF	Set Auto IP(DHCP) On Or Off
NET IP xxx.xxx.xxx.xxx	Set IP Address
NET GW xxx.xxx.xxx.xxx	Set Gateway Address
NET SM xxx.xxx.xxx.xxx	Set Subnet Mask Address
NET TCPPORT ON/OFF	Set TCP/IP Port On Or Off
NET TCPPORT xxxx	Set TCP/IP Port
NET TN ON/OFF	Set Telnet On Or Off
NET TN xxxx	Set Telnet Port
NET RB	Network Reboot And Apply New Config!!!
NET DNS xxxx	Set DNS Domain Name To xxxx (xxxx, Max 16 Characters)

## Certifications

FCC Notice This equipment has been tested and found to comply with the limits for a Class B digital device, pursuant to part 15 of

the FCC Rules. These limits are designed to provide reasonable protection against harmful interference in a residential

installation. This equipment generates, uses, and can radiate radio frequency energy and, if not installed and used in accordance with the instructions, may cause harmful interference to radio communications. However, there is no guarantee that interference will not occur in a particular installation. If this equipment does cause harmful interference

to radio or television reception, which can be determined by turning the equipment off and on, the user is encouraged to

to increase the separation between the equipment and the receiver.

- Connect the equipment into an outlet on a circuit different from that to which the receiver is connected.
- Consult the dealer or an experienced radio/TV technician for help.

CAUTION - changes or modifications not expressly approved by the party responsible for compliance could void the user's authority to operate the equipment.

### CANADA, INDUSTRY CANADA (IC) NOTICES

This Class B digital apparatus complies with Canadian ICES-003.

Operation is subject to the following two conditions: (1) this device may not cause interference, and (2) this device must accept any interference, including interference that may cause undesired operation of the device.

### CANADA, AVIS D'INDUSTRY CANADA (IC)

Cet appareil numérique de classe B est conforme aux normes canadiennes ICES-003.

Son fonctionnement est soumis aux deux conditions suivantes : (1) cet appareil ne doit pas causer d'interférence et (2) cet appareil doit accepter toute interférence, notamment les interférences qui peuvent affecter son fonctionnement.

### CORRECT DISPOSAL OF THIS PRODUCT

This marking indicates that this product should not be disposed with other household wastes. To prevent possible harm to the environment or human health from uncontrolled waste disposal, recycle it responsibly to promote the sustainable reuse of material resources. To return your used device, please use the return and collection systems or contact the retailer where the product was purchased. They can take this product for environmentally safe recycling.



**BLUSTREAM** 

 **FutureVisuals**