

▶ **DA1414**  
User Manual

Thank you for purchasing this product.

For optimum performance and safety, please read these instructions carefully before connecting, operating or adjusting this product. Please keep this manual for future reference.



### Surge Protection Device Recommended

This product contains sensitive electrical components that may be damaged by electrical spikes, surges, electric shock, lightning strikes, etc. Use of surge protection systems is highly recommended in order to protect and extend the life of your equipment.



### Eco Friendly Packaging

This product has been packaged with fully recyclable materials, including compostable bags. Please help us to help the environment.

## Contents

Introduction	03
Front Panel Description	04
Rear Panel Description	04
Resetting the DA1414	06
Operation and Connections	06
Dante® Controller	06
Advanced Dante® Settings	07
Web-GUI - Log In and Initialisation	08
Web-GUI - Control	10
Web-GUI - Input	12
Web-GUI - Output	15
Web-GUI - DSP	18
Web-GUI - Preset	21
Web-GUI - Users	21
Web-GUI - Settings	23
Web-GUI - System	24
Web-GUI - Information	25
Specifications	26
Package Contents	26
Maintenance	26
RS-232 Configuration and Telnet Commands	27
Certifications	31

# Introduction

The DA1414 is a sophisticated PoE powered audio matrix designed for efficient distribution features such as independent routing of mono audio signals, volume control, balance adjustments, up to 8-band parametric equalizer including high/low shelf and high/low pass filtering on the input and output stages.

Equipped with 8x Dante, 4x balanced/unbalanced analogue, and 2x USB audio inputs, it supports output to 8x Dante, 4x balanced/unbalanced analogue, and 2x USB channels. The system includes API switching functionality, allowing users to route Dante channels via third-party control platforms, bypassing Dante Controller or Domain Manager. The analogue inputs also feature selectable 48V phantom power for microphone or line-level connections. Additionally, USB-C / USB-B connectivity options ensure maximum flexibility, catering to diverse system designs.

The DA1414 offers an advanced yet cost-effective solution for seamlessly routing and controlling audio signals within both commercial and residential environments, regardless of the source type.

---

## FEATURES:

---

- 14 x 14 audio Matrix with Dante®, balanced / unbalanced analogue and USB audio
- Supports separation (mono) of all audio channels and independent control resulting in switching of up to 14x14 audio feeds
- Analogue audio inputs support both balanced and unbalanced audio + MIC line level signals
- MIC line level supports 48V Phantom power
- Selectable USB audio between USB-C and USB Type-B inputs with USB audio class 2.0 support
- Supports: volume, balance and up to 8 band parametric equalizer control with high/low shelf and high/low pass filter, per input and output
- Supports 48kHz 24-bit sampling rate for A/D and D/A conversion
- Supports 44.1, 48 & 96 KHz sample rates @ 24 Bit
- Configurable Dante® device latency (supports 2, 3, 4, 5 or 10ms configurable using Dante® Controller)
- Features 2x Dante® LAN ports supporting network redundancy
- Supports AES67 RTP audio transport
- Supports power via PoE+ (Class 4 IEEE 802.3at) on Dante® Primary LAN connection or local power supply
- Control via front panel, RS-232, TCP/IP and web-GUI
- 1U design for 19" rack mount integration - Rack mounting kit included

# Front Panel Description

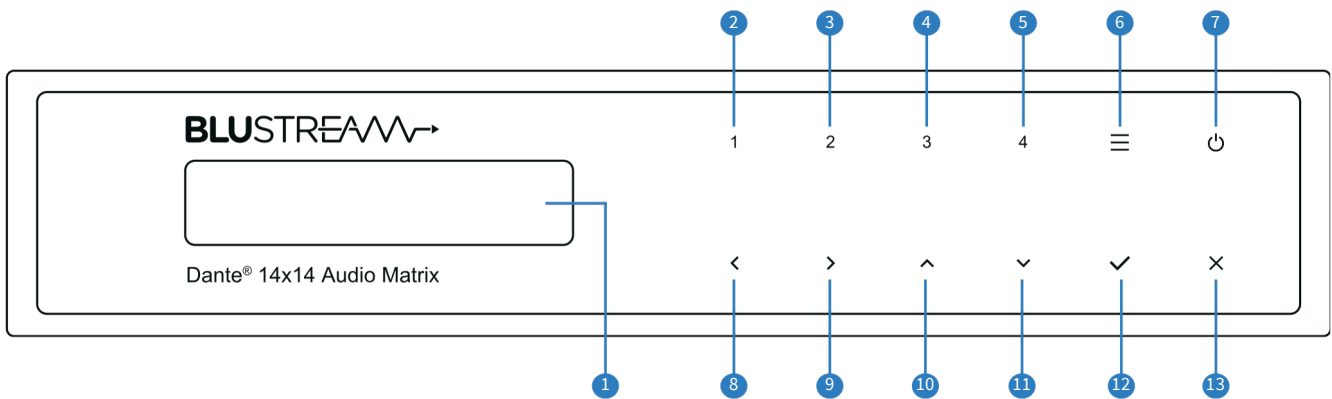

- 1 LCD Display – shows the network status of the DA1414
- 2 DA1414 Analogue Input 1 Button
- 3 Analogue Input 2 Button
- 4 Analogue Input 3 Button
- 5 Analogue Input 4 Button
- 6 Menu Button
- 7 Power Button

- 8 Left Button
- 9 Right Button
- q Up Button
- w Down Button
- e Confirm Button
- r Cancel Button

# Rear Panel Description

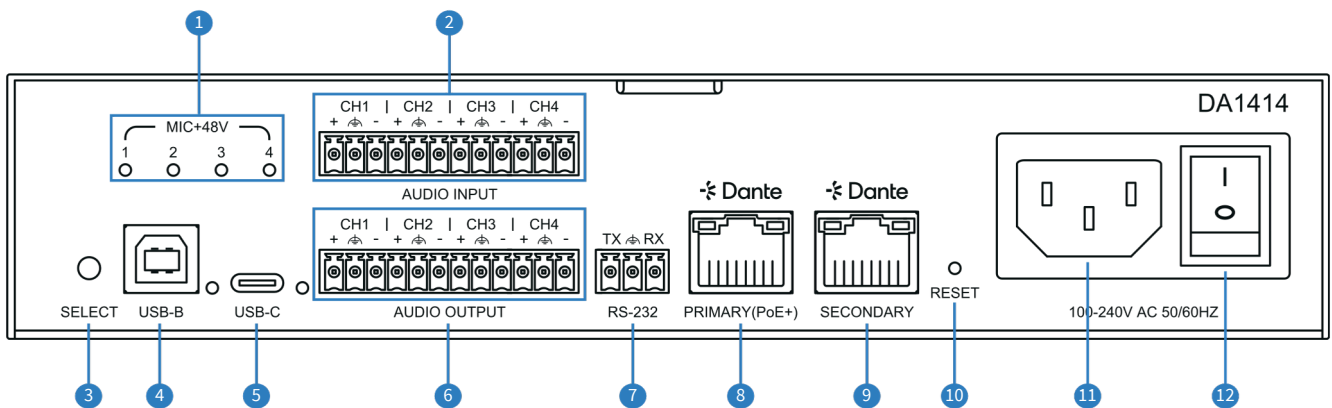

- 1 Phantom Power Input Indicator – displays which input has phantom power applied
- 2 4 x 3-pin Phoenix Connector Analogue Audio Inputs – supports both balanced and unbalanced signals including 48V phantom power
- 3 USB Select Button – selects which USB port is active
- 4 USB-B Input Connector – the LED will illuminate when this port is active
- 5 USB-C Input Connector – the LED will illuminate when this port is active

- 6 4 x 3-pin Phoenix Connector Analogue Audio Outputs – supports both balanced and unbalanced signals
- 7 1 x 3-pin Phoenix Connector – for RS-232 serial control
- 8 1 x TCP/IP RJ45 Port (Dante and PoE Enabled)
- 9 1 x TCP/IP RJ45 Port (Dante Enabled) – the DA1414 will only allow 1 network connection at a time, the secondary RJ45 port is for network redundancy
- q Reset Button
- w Mains C14 IEC Power Inlet
- e Mains Power Switch

**BLUSTREAM**

**Example Schematic  
DA1414**

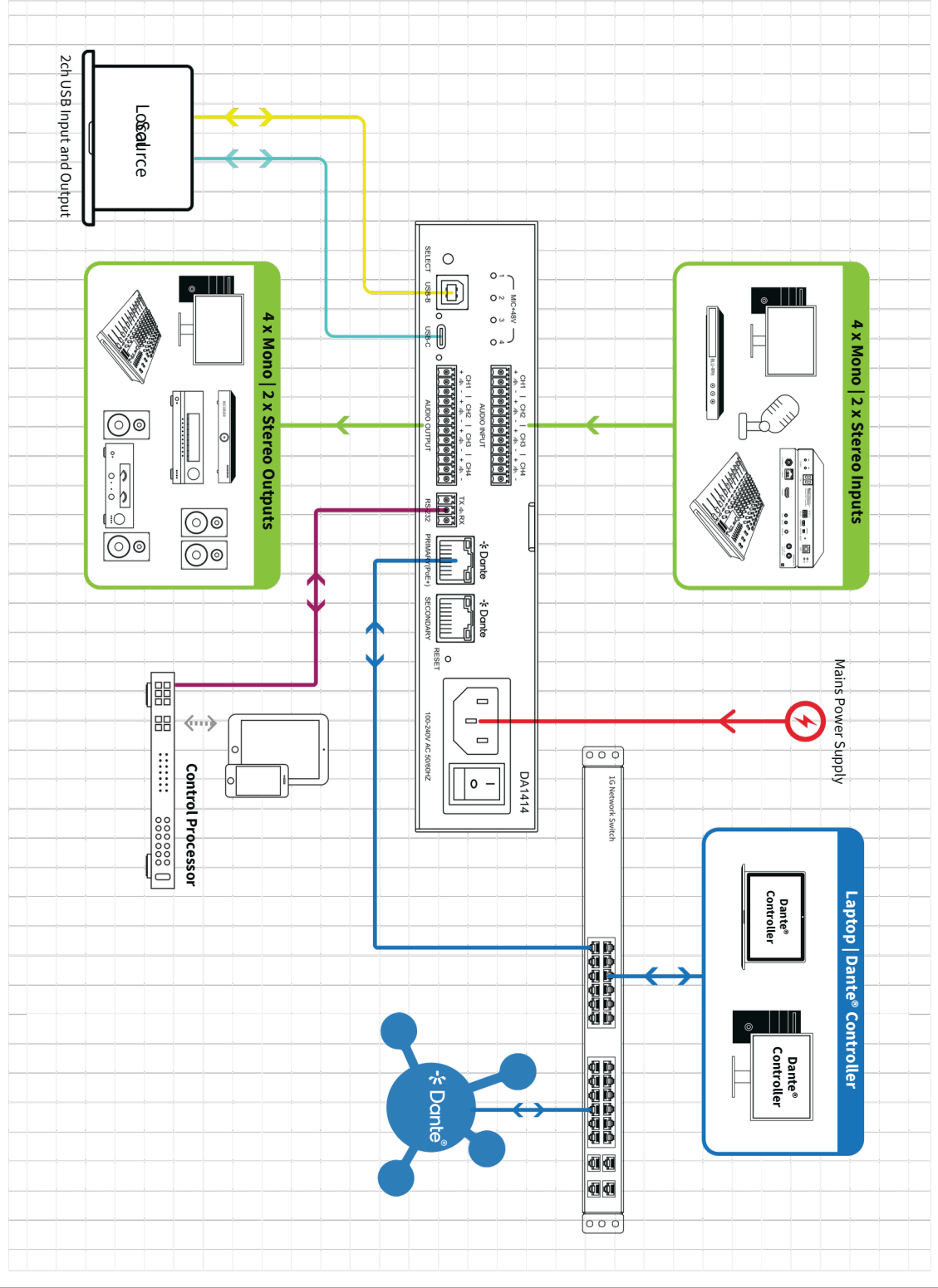
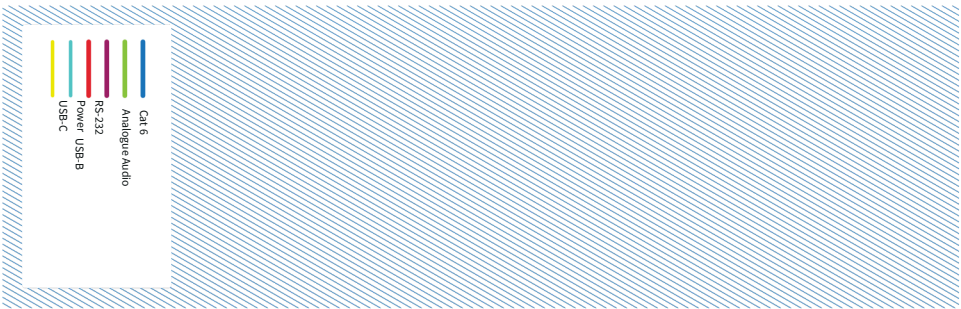

## Resetting the DA1414

To reset the DA1414 back to factory default, use a small instrument to press down the recessed button on the back of the unit labelled RESET. Hold for at least 10 seconds before releasing.

The reset process takes approximately 30 seconds.

## Operation and Connections

Basic operation of the DA1414 can be achieved via the front and rear panel: connect the audio input and audio output devices, the TCP/IP port, and power to the rear of the unit:

- Buttons 1-4 will allow for configuration of the analogue audio inputs and phantom power
- The Menu Button will scroll through a few functions of the DA1414
- The menu can be navigated using the arrow, confirm and cancel buttons

For full configuration of the DA1414, the Dante Controller software and the in-built Web-GUI must be utilised.

## Dante® Controller

The Dante® Controller software is required in order to setup and configure the DA1414 as well as control a Dante® network.

Audinate provide extensive training videos and documentation on their website, which can be found here: <http://www.audinate.com/products/software/dante-controller>

Upon connecting the DA1414 to a compatible network, the Dante® Controller software should automatically discover the device. The DA1414 will appear in the Dante® Controller as 'DA1414-xxxxxx'. On the Routing tab, audio can be routed as a matrix between Dante® transmitters and receivers in your system.

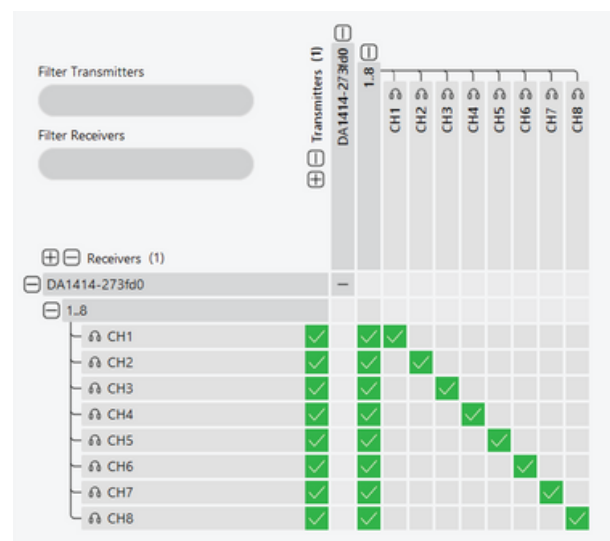
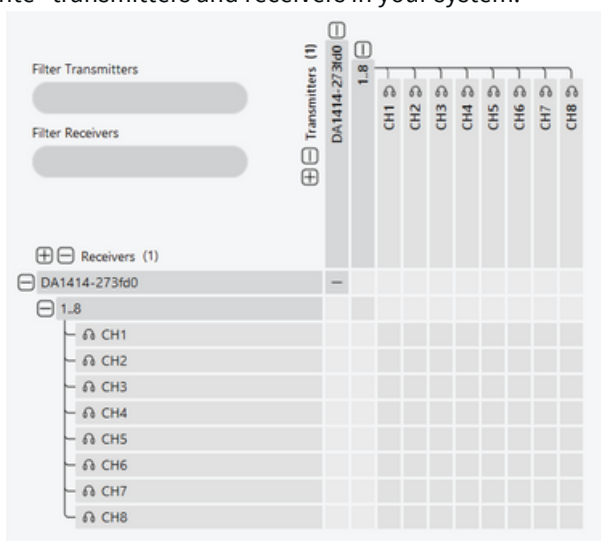

The DA1414 is shipped with its network settings set to obtain an IP Address automatically; if a DHCP server is present on your network, it will provide the DA1414 with an IP Address. If no DHCP server is present then the DA1414 will receive a default IP Address in the 169.254.xxx.xxx range.

# Advanced Dante® Settings

Further settings of the DA1414 can be configured in the Dante® Controller software. Under the Device Info tab, select the DA1414 to open the Device View window.

Routing		Device Info			Clock Status	Network Status		Events	
Device Name	Model Name	Product Version	Dante Version	Device Lock	Primary Address	Primary Link Speed	Secondary Address	Secondary Link Speed	
DA1414-273fd0	DA1414	1.0.1	1.3.3.5	<input type="checkbox"/>	10.0.0.103	1Gbps		Link down	

1 devices      Multicast Audio Bandwidth: 0 bps      Event Log ■      Clock Status Monitor ■

The sample rate and latency can be adjusted under the Device Config tab, while network settings and the IP address can be set under the Network Config tab.

Please note: That Dante® products can only transmit or receive audio from other Dante® products that are set up with the same sample rate. A mismatch in sample rate may stop audio from transmitting.

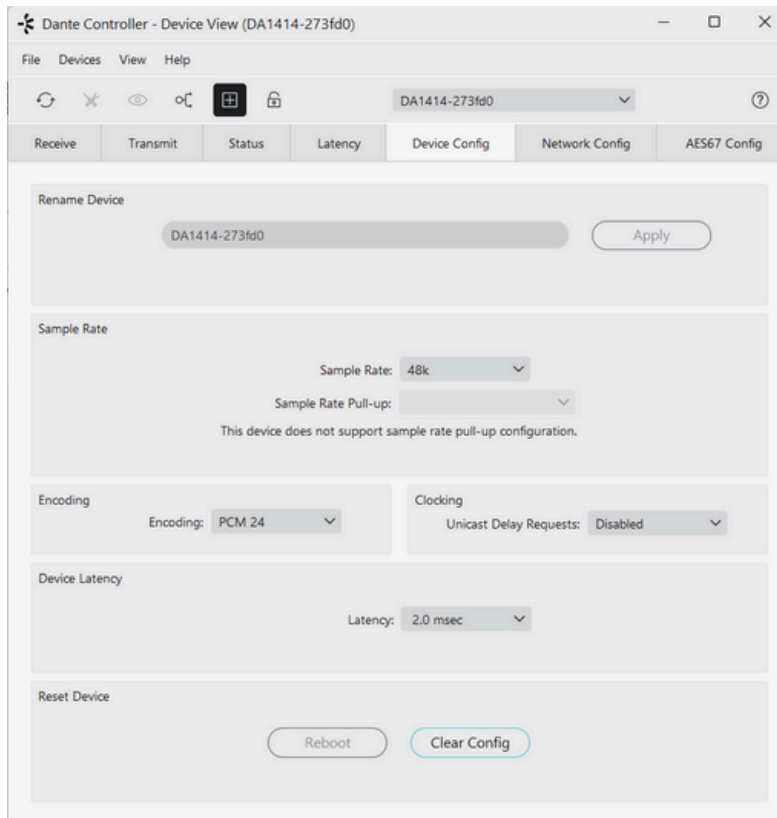

## Web-GUI - Log In and Initialisation

The following pages will take you through the operation of the units web-GUI. You must connect a TCP/IP RJ45 socket to your local network, or directly from your computer to the DA1414, in order to access the product's web-GUI.

By default, the unit is set to DHCP; however, if a DHCP server (eg: network router) is not installed, the unit's IP address will revert to below details:

Default IP Address is: [192.168.0.200](#)

Default Admin Username is: [blustream](#)

Default Admin Password is: [@Bls1234](#)

The DA1414 is able to be accessed via it's hostname if the IP address is not known:

Default mDNS is: [da1414.local](#)

### Login Page:

The web-GUI supports multiple users along with multiple user permissions as follows:

- Admin (Blustream)                      The Admin account allows full access to all functions and configuration of the unit.
- User Accounts                              User accounts can be utilised, each with individual login detail and can be assigned permissions to specific areas and functions.
- Guest    When enabled, the control page can be accessed without logging in.

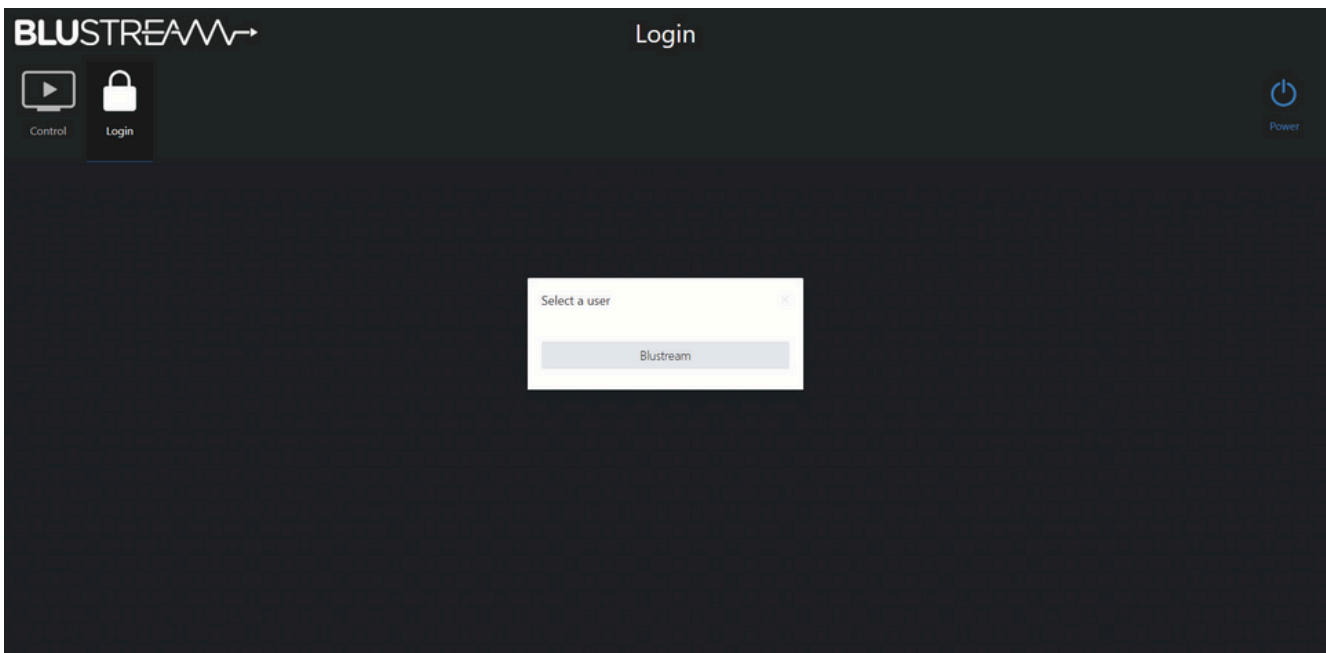

Please note: the first time the Administrator logs into the web-GUI of the DA1414, the default password must be changed to a unique password. Please retain this password for future use. Forgetting the password will mean having to factory reset the unit, losing all prior network and configuration settings.

New password regulations requires passwords being set for products to be a minimum of 8 characters and contain a minimum of: 1 x uppercase letter, 1 x lowercase letter, 1 x symbol and 1 x number.

## Login Page (continued)

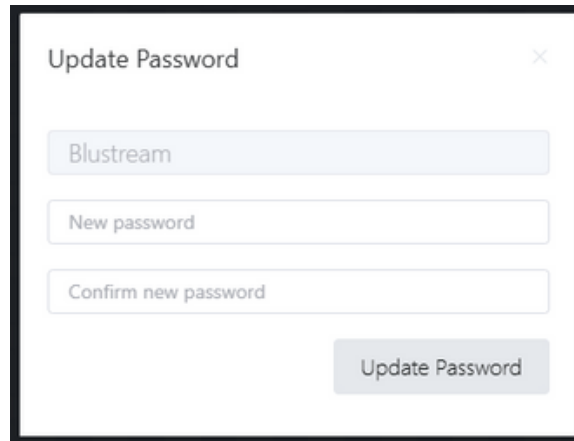

Update Password

Blustream

New password

Confirm new password

Update Password

## Guest Control Page:

When the Guest user is enabled, the control page is able to be accessed from the web-GUI without logging in. Depending on the permissions set, control for the Matrix, Phantom Power, Inputs & Outputs, DSP and Presets can be accessed from here.

Permissions can be set or revoked from the Users page when logged in, depending on the requirements of the installation. It is recommended to set permissions for the Guest user to avoid unwanted access and/or changes to the DA1414 system.



## Web-GUI - Control

After logging into the DA1414, the user will be directed to the Control page. Configuration of the matrix can be done here, as well as recalling presets as needed.



### Routing Matrix:

For any audio sources connected to be able to output a signal, it must be routed in the Routing Matrix. Input channels are listed as columns along the x-axis, and output channels are listed as rows along the y-axis.

To route a signal, navigate to the desired input channel. In the column under the input name, find the row that corresponds to the desired output channel, and press the button that intersects the desired column and row.

In the following examples, the x-axis will be labelled 1-14 left to right, and the y axis will be labelled 1-15 top to bottom.

- To route Analogue Input CH1 to Analogue Output CH1, select the button in position (1,1)
- To route Dante Input CH1 to Dante Output CH1, select the button in position (5,5)

**Routing Matrix (continued)**

- To route Analogue Input CH1 to All Outputs, select the button in position (1,15)

	Analogue Input CH1	Analogue Input CH2	Analogue Input CH3	Analogue Input CH4	Dante Input CH1	Dante Input CH2	Dante Input CH3	Dante Input CH4	Dante Input CH5	Dante Input CH6	Dante Input CH7	Dante Input CH8	USB Input Left	USB Input Right
Analogue Output CH1	Blue													
Analogue Output CH2	Blue													
Analogue Output CH3	Blue													
Analogue Output CH4	Blue													
Dante Output CH1	Blue													
Dante Output CH2	Blue													
Dante Output CH3	Blue													
Dante Output CH4	Blue													
Dante Output CH5	Blue													
Dante Output CH6	Blue													
Dante Output CH7	Blue													
Dante Output CH8	Blue													
USB Output Left	Blue													
USB Output Right	Blue													
All Output	Blue													

- To route an input to multiple outputs, select the desired outputs in that input's column

Please note: Channels linked as stereo pairs will cause the matrix to group their channels into a single button for ease of selection.

**Recall Preset:**

To recall a saved preset, simply press the desired preset button. Presets can be saved and configured from the preset page in the web-GUI.

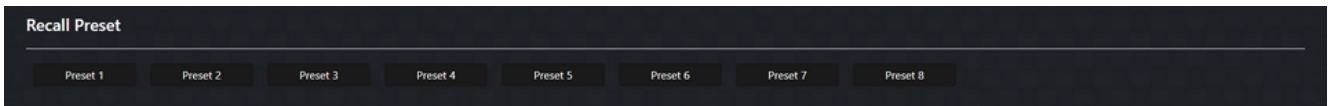

## Web-GUI - Input

The Input page allows for adjustment and configuration of all input sources, including grouping options for ease of control. To change the name of an input, type a new name into the desired label for the corresponding input.

The input level sensitivity can be adjusted from -30dB to +30dB by using the corresponding slider for the desired channel.

Fine-tuning of the sensitivity can be achieved by using the increment button 1 or the decrement button 3, or by manually inputting the value 2. The channel can be muted by pressing the mute button 4.

Please note: The input gain adjustment is designed to adapt to different input amplitudes. When the input gain is adjusted beyond 0dB, if the incoming audio signal level is too high, it is possible to distort the input signal.



Channels can be linked as stereo pairs by pressing the CHx/CHx Stereo toggle.

Please note: If the stereo toggle is on, channels will be treated as a L/R stereo pair (i.e., CH1/CH2, CH3/CH4, etc.) and will apply changes made to the corresponding channel also.

**Analogue Input:** The DA1414 supports both line level input and microphone input including 48V phantom power. Phantom power can be enabled by toggling the Phantom Power switch for the desired channel. **WARNING:** Phantom power has the potential to damage equipment that it isn't designed for. Always turn off phantom power, then plug in the microphone, and only then turn on phantom power if the microphone requires it. Always turn off phantom power before unplugging the microphone.

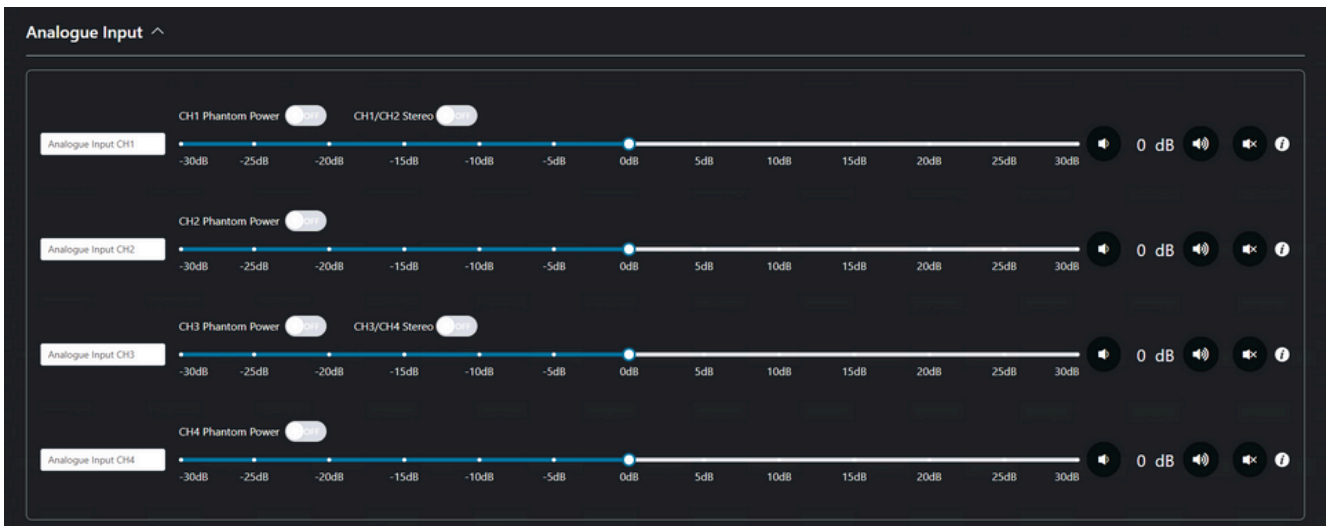

**Dante Input:**

The DA1414 can route audio to and from other Dante audio devices.

This must be set in the Dante Controller App. Please refer to the Dante section of the manual.

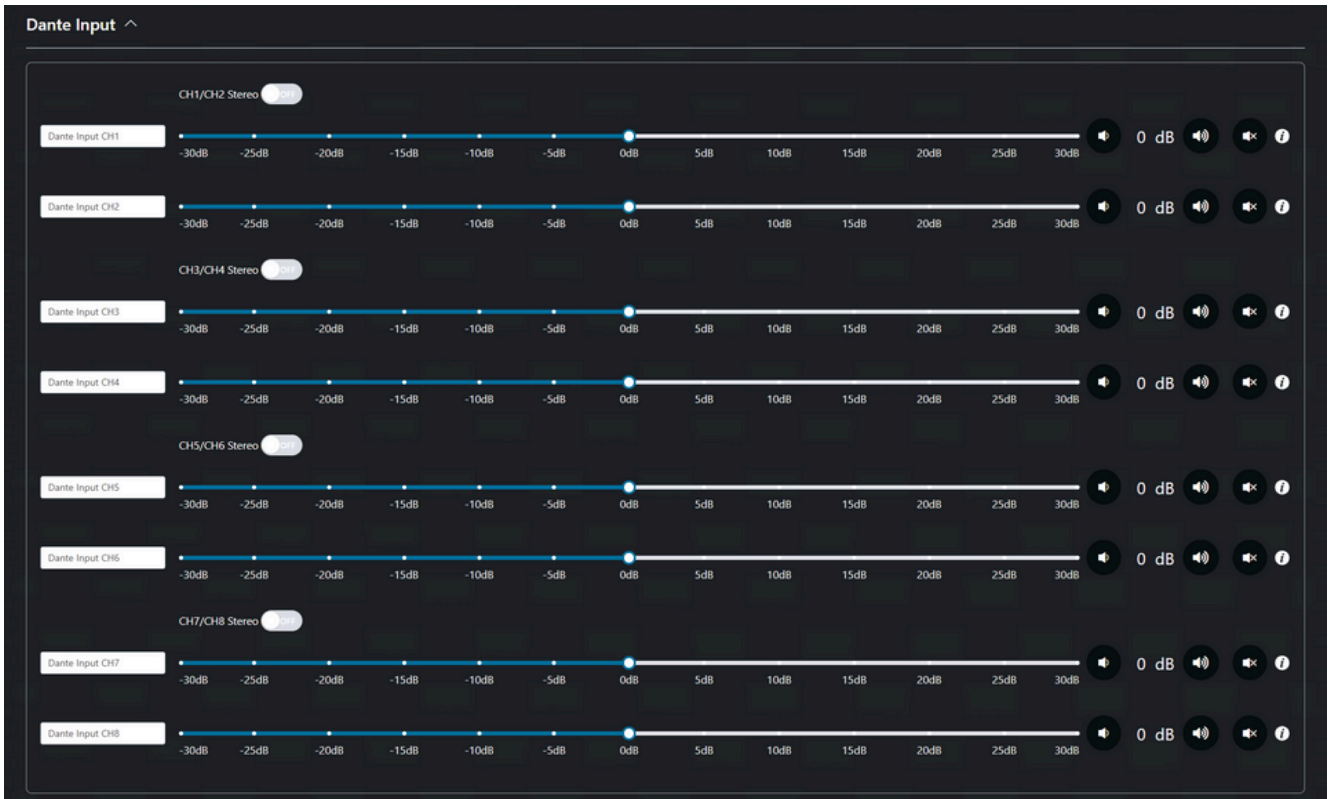

**USB Input:**

The DA1414 can send and receive audio from a USB device. Connect the device to either the USB-B or USB-C port and select the desired port on the web-GUI.

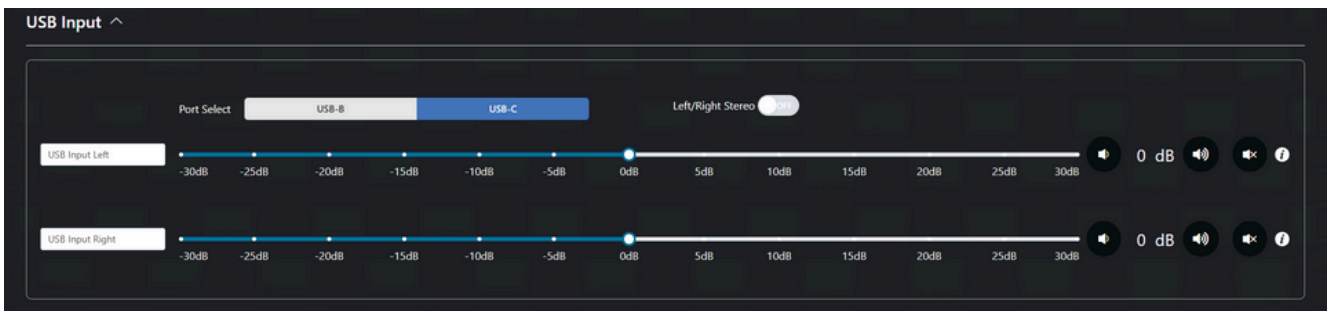

### Input Group:

The grouping feature allows you to combine audio input channels resulting in a single volume and source control for multiple inputs. Up to four groups can be used simultaneously.

Use the channel toggles to assign inputs to a group; each channel can only be assigned to a single group.

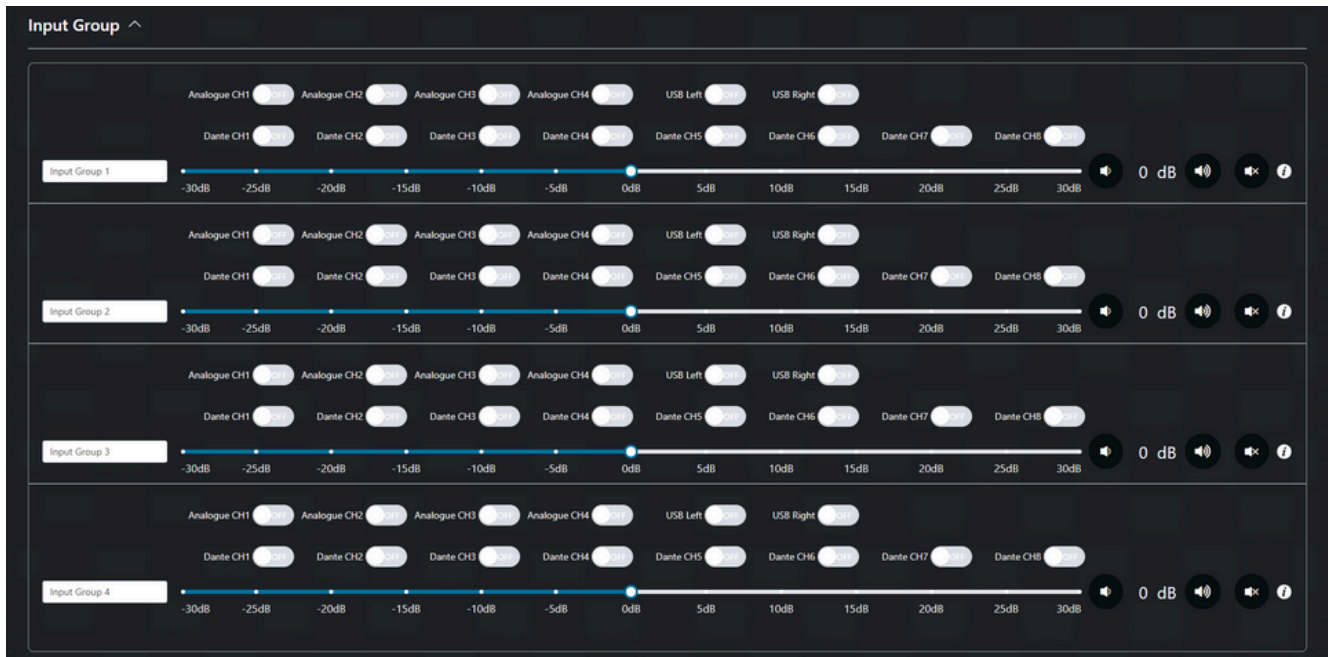

## Web-GUI - Output

The Output page allows for adjustment and configuration of all outputs, including grouping options for ease of control. To change the name of an output, type a new name into the desired label for the corresponding output.

The output volume can be set by moving the slider left or right for the desired channel.

Fine-tuning of the volume can be achieved by using the decrement button **1** or the increment button **3**, or by manually inputting the value **2**. The channel can be muted by pressing the mute button **4**.

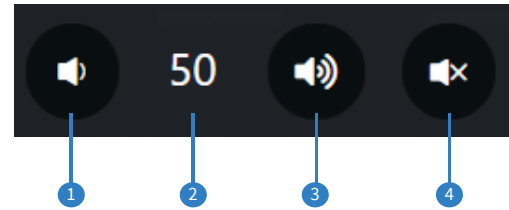

A delay can be set between 0ms and 50ms by using the delay slider above each output channel. This can be used to rectify lip sync and other similar issues.

Channels can be linked as stereo pairs by pressing the CHx/CHx Stereo toggle.

Please note: If the stereo toggle is on, channels will be treated as a L/R stereo pair (i.e., CH1/CH2, CH3/CH4, etc.) and will apply changes made to the corresponding channel also.

### Analogue Output:

The supports both balanced and unbalanced audio output, including from devices connected to the Dante® network



**Dante Output:**

The DA1414 can route audio to and from other Dante audio devices.

This must be set in the Dante Controller App. Please refer to the Dante section of the manual.



**USB Output:**

The DA1414 can send and receive audio from a USB device. Connect the device to the either the USB-B or USB-C port, and ensure the desired port is active.

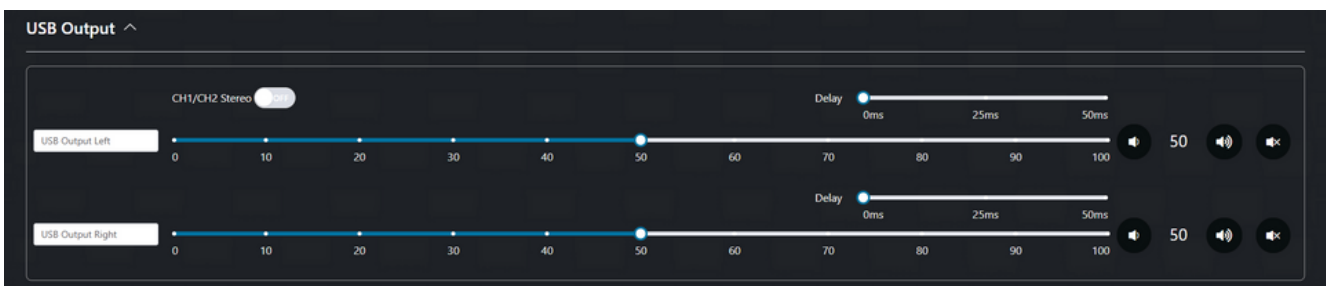

**Output Group:**

The grouping feature allows you to combine audio output channels resulting in a single volume and source control for multiple outputs. Up to four groups can be used simultaneously.

Use the channel toggles to assign outputs to a group; each channel can only be assigned to a single group.

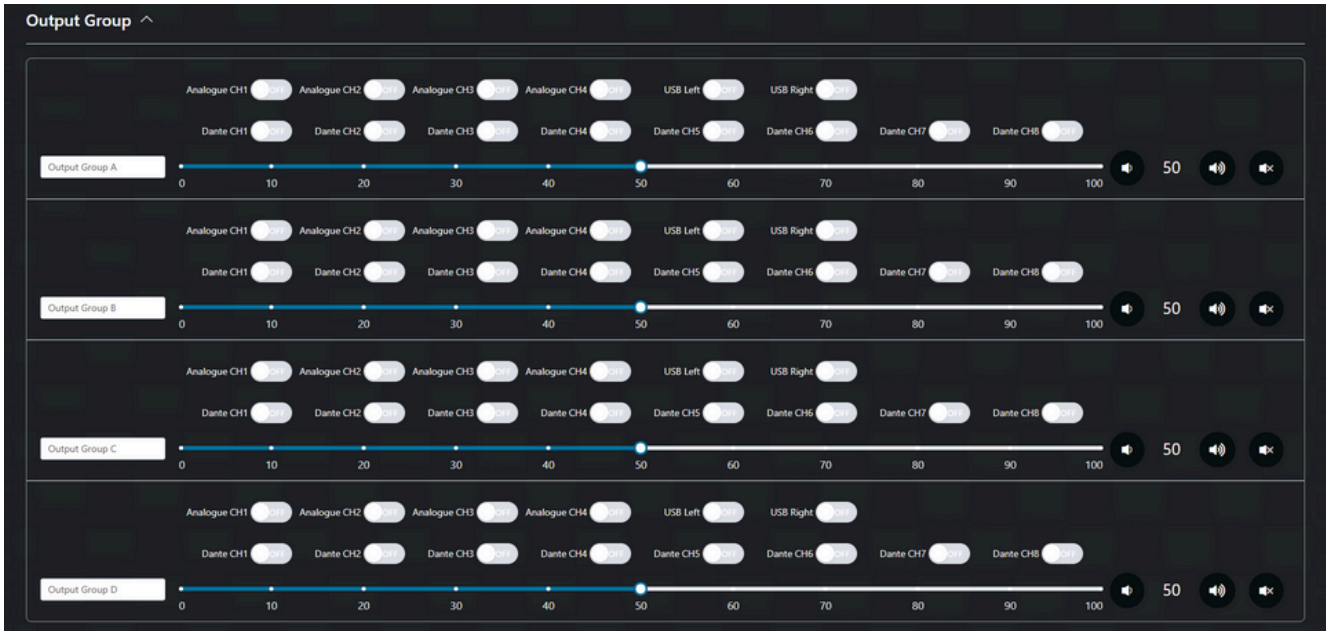

# Web-GUI - DSP

The DA1414 features an in-built DSP featuring a graphic parametric equaliser (PEQ) with up to 8 bands. All input channels, output channels and group channels, can access the PEQ independently and save their equaliser settings to a custom preset.

The screenshot displays the DSP configuration interface for the BLUSTREAM DA1414. It is divided into two main sections: 'Input PEQ' and 'Output PEQ'. Each section includes a channel selector, a stereo toggle, and an equalizer preset dropdown. Below these are frequency response graphs and a table of 8 parametric filter bands. The 'Input PEQ' section is currently selected, showing 'Analogue Input CH1' as the channel and 'Stereo' as ON. The equalizer is set to 'Flat'. The frequency response graph shows a flat line at 0dB across the 20Hz to 20kHz range. The filter table below the graph shows all 8 bands set to 'Parametric' with a gain of 0.0 dB, a frequency of 32 Hz, and a Q factor of 1.41.

**Input PEQ**

Channel: Analogue Input CH1 | Stereo: ON | Equalizer: Flat

Gain [dB] vs Frequency [Hz] graph showing 8 filter bands.

Band	Filter Type	Gain [dB]	Frequency [Hz]	Q
1	Parametric	0.0	32	1.41
2	Parametric	0.0	80	1.41
3	Parametric	0.0	200	1.41
4	Parametric	0.0	500	1.41
5	Parametric	0.0	1250	1.41
6	Parametric	0.0	3150	1.41
7	Parametric	0.0	8000	1.41
8	Parametric	0.0	12000	1.41

**Output PEQ**

Channel: Analogue Output CH1 | Stereo: ON | Equalizer: Flat

Gain [dB] vs Frequency [Hz] graph showing 8 filter bands.

Band	Filter Type	Gain [dB]	Frequency [Hz]	Q
1	Parametric	0.0	32	1.41
2	Parametric	0.0	80	1.41
3	Parametric	0.0	200	1.41
4	Parametric	0.0	500	1.41
5	Parametric	0.0	1250	1.41
6	Parametric	0.0	3150	1.41
7	Parametric	0.0	8000	1.41
8	Parametric	0.0	12000	1.41

**Input/Output PEQ:**

To modify a channel’s PEQ settings, select the desired channel from the dropdown list. A graphic visualisation of the PEQ is shown, as well as parameters for precise control.

Please note: If the stereo toggle is on, channels will be treated as a L/R stereo pair (i.e., CH1 & CH2, CH3 & CH4, etc.) and will apply changes made in the PEQ to the corresponding channel.

There are 3 presets for the equaliser: Flat, Custom 1 and Custom 2.

- The Flat preset will disable the PEQ for that channel and cannot be edited.
- Custom 1 and Custom 2 allow the graphic equaliser to be edited: simply drag and drop the numbered bands on the graphic equaliser

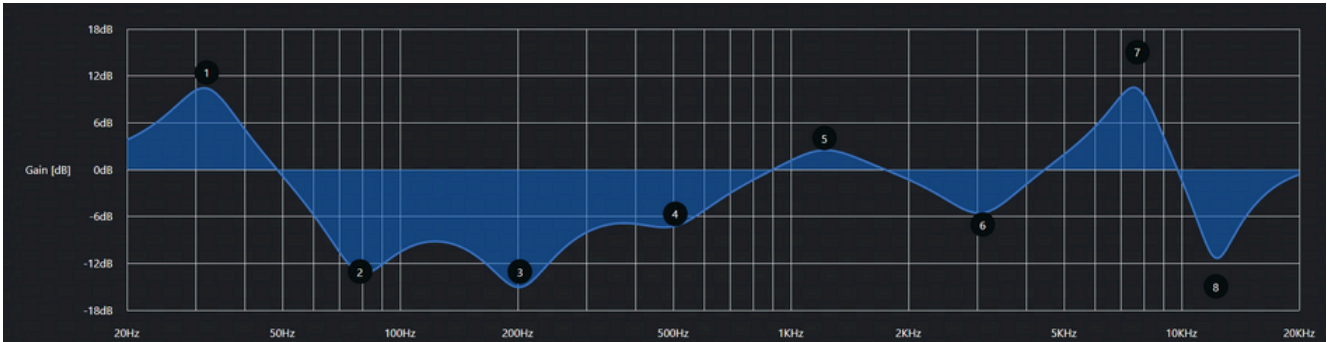

**Parameters:**

If an EQ band is not required, press the band’s label in the parameters section to disable it.

The filter type of the band can be change to the following filters:

**Parametric**

- Each parametric EQ (PEQ) allows you to make a cut or a boost to a band on the frequency spectrum. ‘Freq’ will set the centre frequency on the band which will be the centre of the bell shaped boost or cut.

Gain will set the amount of boost or cut being applied.

Q refers to how narrow or wide the boost or cut is. The higher the Q value, the narrower the bandwidth will be. Similarly, the lower the Q value, the wider the bandwidth will be.

A visual example showing the effect the Q value has on the shape of the curve is shown below.

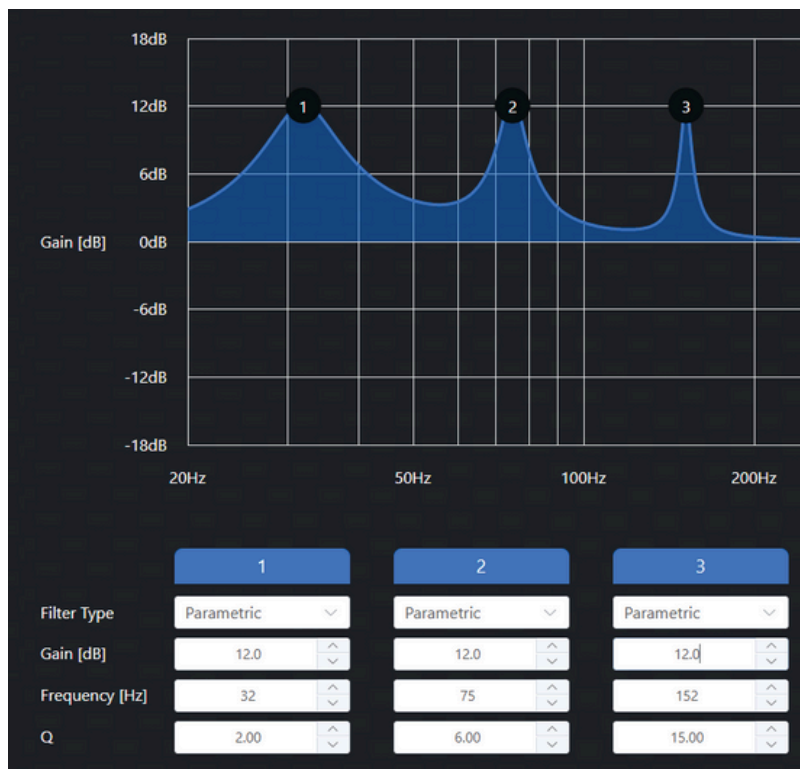

**Parameters (continued)**

**Low Pass Filter**

- A Low Pass Filter removes high frequencies while allowing low frequencies to pass through. Setting the 'Freq' will attenuate all frequencies above the set frequency. The slope determines the rate of attenuation, measured in decibels (dB) per octave. Setting this to zero will disable the Low Pass Filter. Drastic attenuation over a small range of frequencies, or gradual attenuation over a larger range of frequencies, can be achieved by adjusting the slope.

**High Pass Filter**

- A High Pass Filter removes low frequencies while allowing high frequencies to pass through. Setting the 'Freq' will attenuate all frequencies below the set frequency. The slope determines the rate of attenuation, measured in decibels (dB) per octave. Setting this to zero will disable the High Pass Filter. Drastic attenuation over a small range of frequencies, or gradual attenuation over a larger range of frequencies, can be achieved by adjusting the slope.

**Low Shelf**

- A Low Shelf represents a flat raise or drop of all frequencies below the 'Freq' value. This leaves the frequencies above this spot untouched by the Low Shelf.

**High Shelf**

- A High Shelf represents a flat raise or drop of all frequencies above the 'Freq' value. This leaves the frequencies below this spot untouched by the High Shelf.

To quickly apply a DSP configuration, the Custom 1 and Custom 2 presets can be pre-configured and quickly changed to by pressing the corresponding button.

Press the Reset button to set the Custom 1 / Custom 2 preset back to it's original state.

**Usage:**

Using the DSP, it's possible to configure many different setups, e.g., a subwoofer channel by changing the Audio Mode from the Output page and using the Low Shelf to EQ the signal.

An example of a fully configured setup has been provided below:

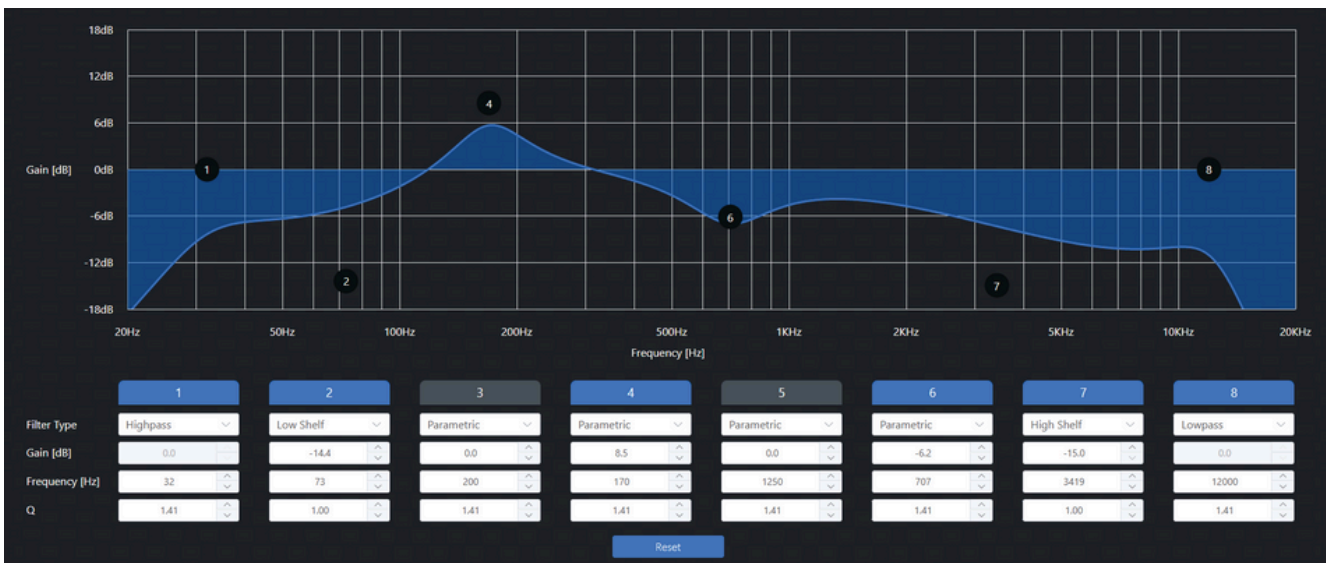

## Web-GUI - Preset

Once the DA1414 has been set up, the current configuration can be saved to a preset. If multiple presets are saved, they can be quickly switched between from the Preset page or the Control page.

A preset can be named by entering the name into the Preset Name field.

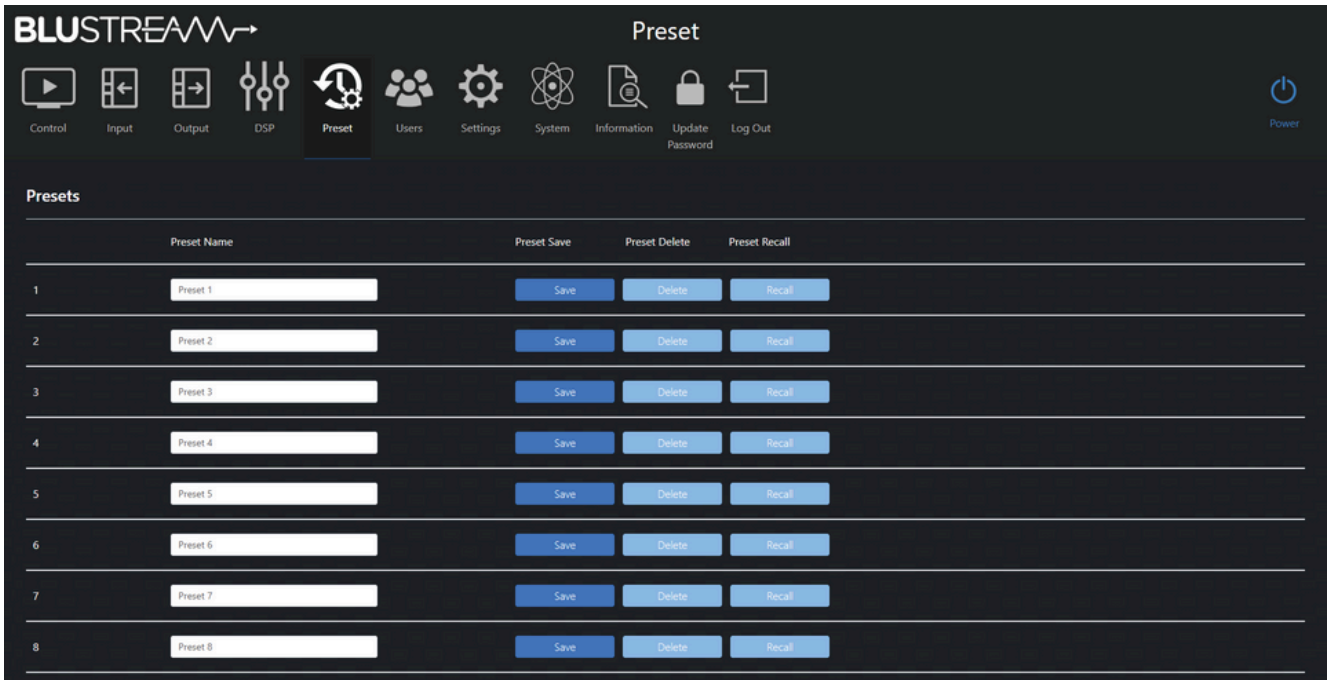

To save the current configuration to a preset, press the Save button.

The saved preset can now be recalled via the Recall button.

To delete a preset, press the Delete button.

## Web-GUI - Users

The DA1414 can be set up with different levels of access to the web-GUI per user. Access can be restricted based on which channels the users can see and configure, and which presets the user can select, and which pages remain accessible.

Please note: A separate user should be set up and used after installation of the unit in order to prevent non-administrator users from changing settings and potentially damaging connected equipment.

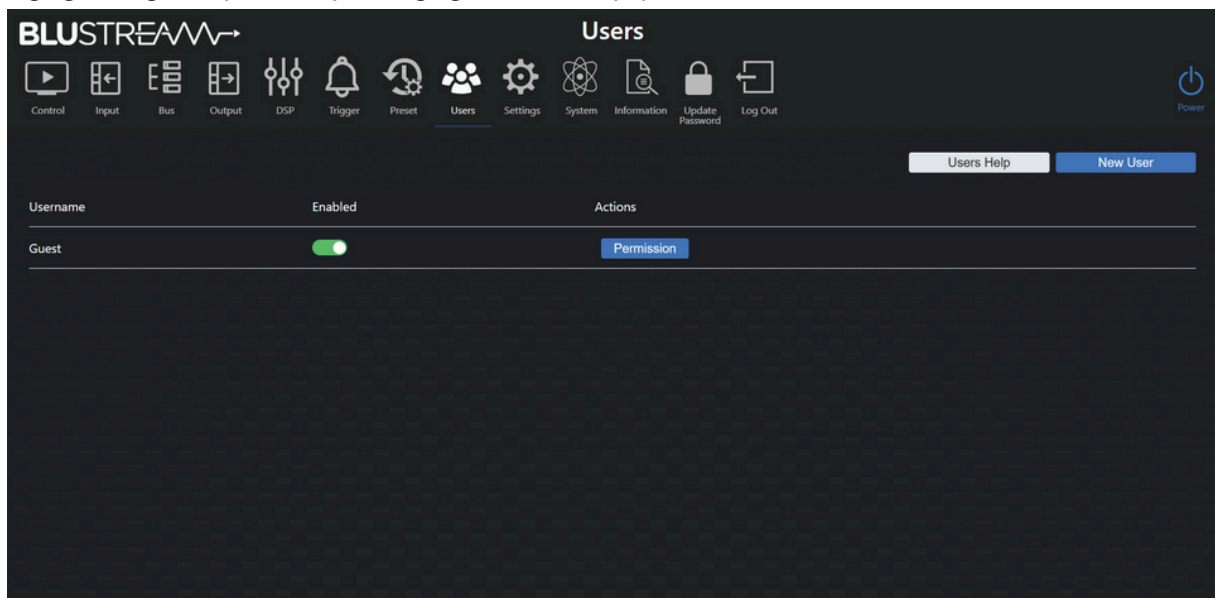

**Web-GUI Users (continued)**

To create a new user, press the New User button. Set a username and password and press Create.

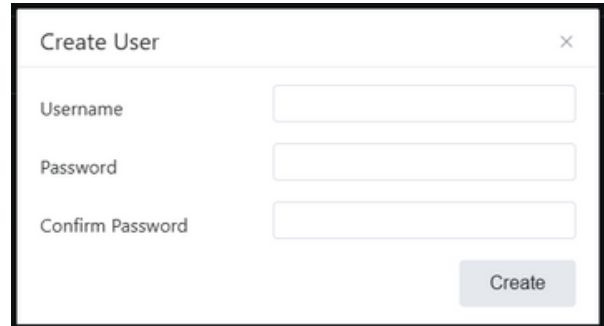

The new user will appear in the list.

To enable / disable a user, press the respective toggle.

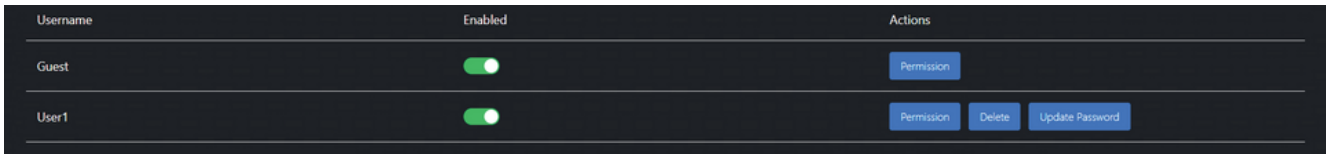

Press the Permissions button in order to modify the permissions for that user in a sub menu.

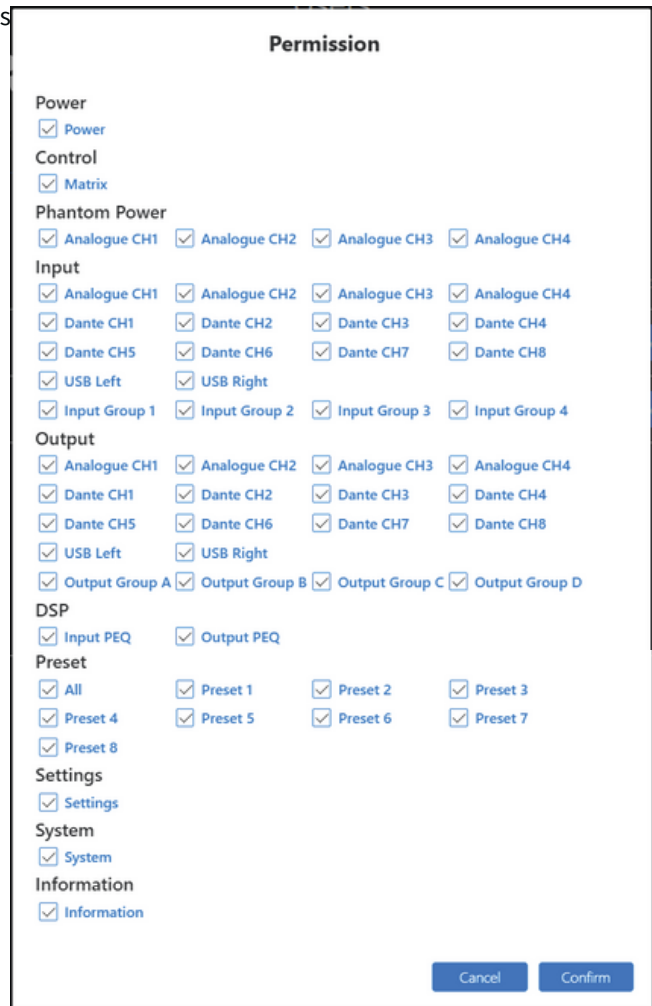

To delete a user, press the respective Delete button.

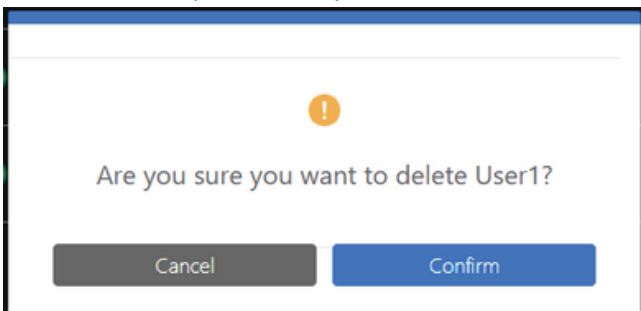

To change the password for a user, press the respective Update Password button

Please note: Admin (blustream) and Guest user cannot be deleted. The guest user should either have permissions set or be disabled to prevent unwanted access, as they do not require credentials for control of the unit.

## Web-GUI - Settings

Network settings for the DA1414 can be configured from this page, such as: IP settings, Telnet and mDNS.

The default network settings can be restored by pressing the Set Network Defaults button.

To save the current network configuration, press the Save button.

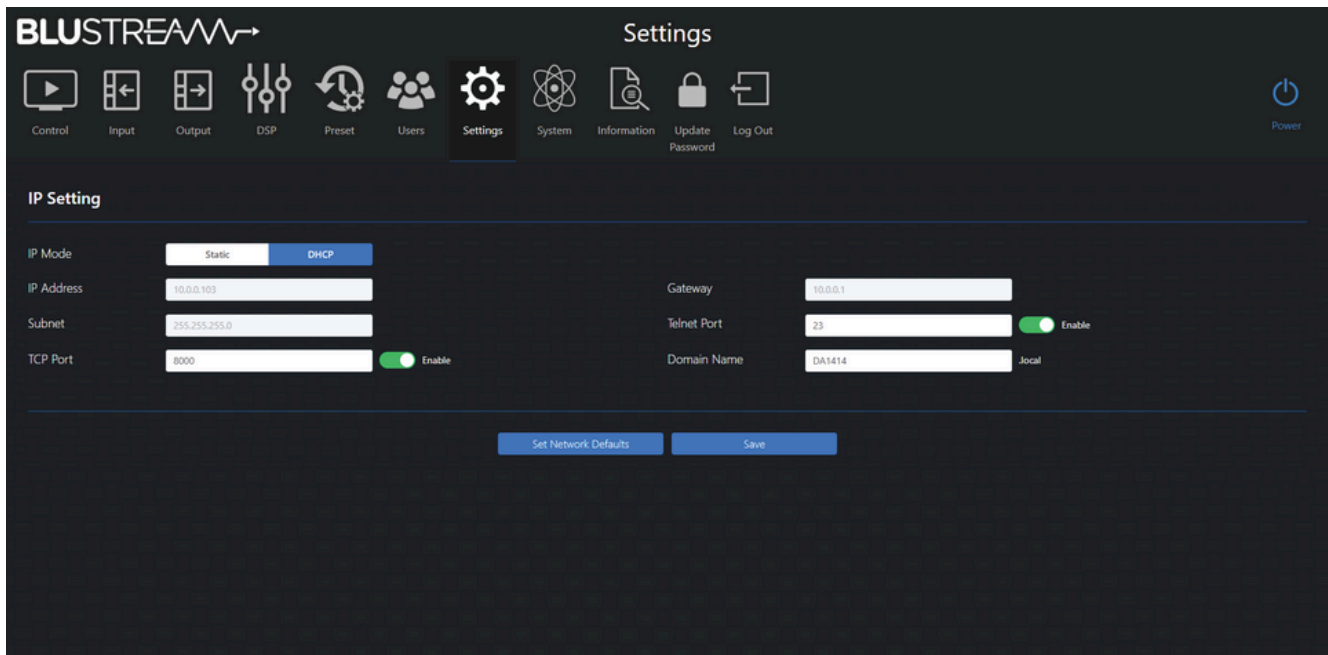

### IP Settings:

- IP Mode
  - Static / DHCP
- IP Address
  - Disabled when in DHCP mode
- IP Subnet
  - Disabled when in DHCP mode
- TCP Port
  - Enable / Disable (default: 8000)
- Gateway
  - Disabled when in DHCP mode
- Telnet Port
  - Enable / Disable (default: 23)
- Domain name (mDNS)
  - mDNS is a protocol used in network environments to resolve hostnames to IP addresses within local networks without the need for a dedicated DNS server. The DA1414 is able to be accessed via the hostname if the IP address is not known. By default this is set to da1414.local

To restore network default settings, press the Set Network Defaults button.

Press the Save button to apply any changes made.

## Web-GUI - System

The System page allows for configuration of the DA1414, enabling and disabling features, as well as firmware upgrading and factory resetting.



### Power

Set the system power to on or off

### Standby Mode

There are two standby modes that can be selected:

- Sleep                    the unit will power off but the API and web-GUI remain active
- Standby                 the DSP board remains powered allowing the signal sensing feature to power on the unit

### Key Lock

Lock or unlock the front panel buttons

### Front Panel Lights

Set the duration the LEDs on the front panel of the unit will remain on for.

If the Include Power LED box isn't checked, it will act independently to the rest of the front panel LEDs.

### Serial Baud Rate

Select the Baud Rate for the RS-232 Serial port

9600/19200/38400/57600/115200

### MCU Update

Browse your device for an MCU firmware file to upload to the unit.

## Web-GUI - System (continued)

### DEP SDK Update

Browse your device for a DEP firmware file to upload to the unit.

### Factory Reset (Excludes Network Settings)

Erases all settings, expect for network settings, and reboots the unit.

### Factory Reset All (Includes Network Settings)

Erases all settings and reboots the unit.

### Reboot

Reboots the unit.

## Web-GUI - Information

The Information page displays the model name, serial number, web-GUI firmware version and MCU firmware version of the DA1414. It also displays network configuration, temperature and uptime data.

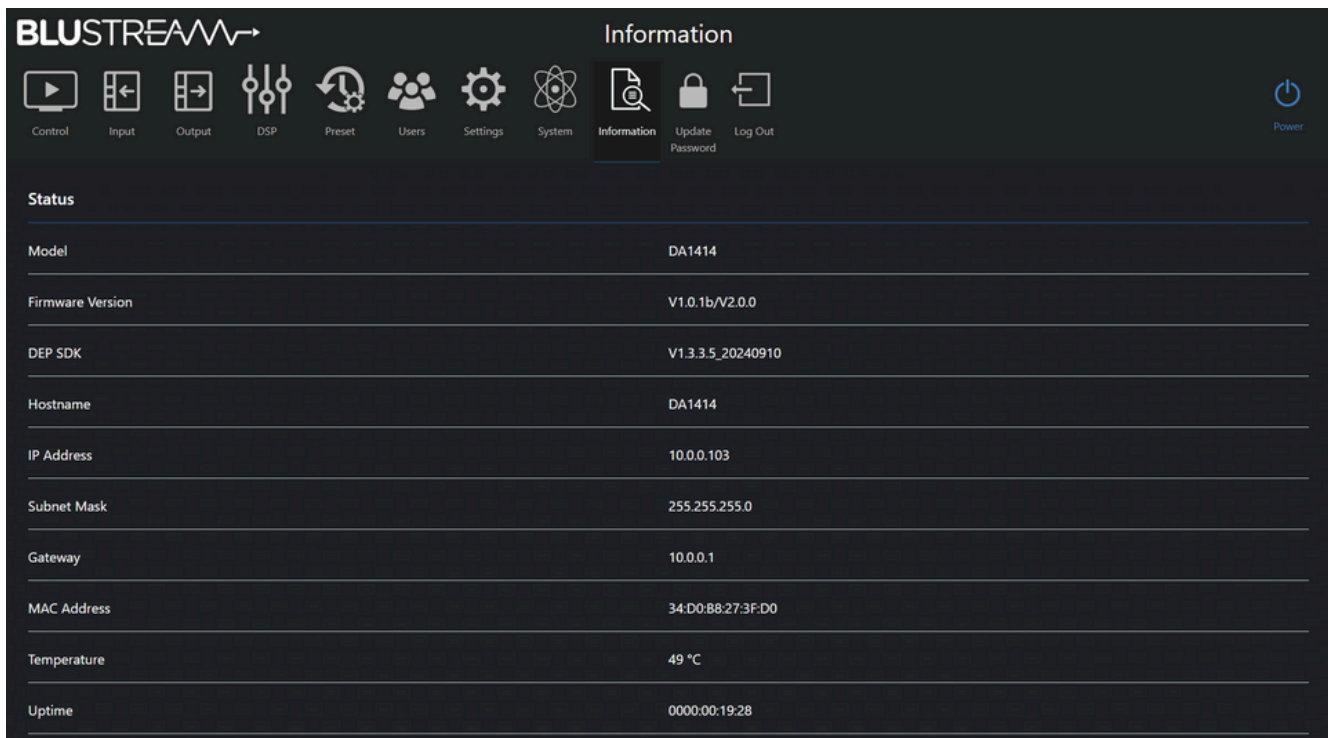

Status	
Model	DA1414
Firmware Version	V1.0.1b/V2.0.0
DEP SDK	V1.3.3.5_20240910
Hostname	DA1414
IP Address	10.0.0.103
Subnet Mask	255.255.255.0
Gateway	10.0.0.1
MAC Address	34-D0-B8-27-3F-D0
Temperature	49 °C
Uptime	0000:00:19:28

## Specifications

- **Audio Input Connectors:** 2x RJ45, female (1Gb Dante™ Primary/Secondary network), 12-PIN Phoenix connector (4CH balanced/unbalanced analogue audio/MIC), USB-B, USB-C
- **Audio Output Connectors:** 2x RJ45, female (1Gb Dante™ Primary/Secondary network), 12-PIN Phoenix connector (4CH balanced/unbalanced analogue audio/MIC), USB-B, USB-C
- **RS-232 serial port:** 1 x 3-Pin Phoenix connector
- **TCP/IP Control:** 2 x RJ45, female (1Gb Dante™ Primary/Secondary network)
- **Casing Dimensions (W x D x H):** 437mm x 245mm x 44mm
- **Dimensions Including Connections (W x D x H):** 437mm x 252mm x 44mm
- **Shipping Weight:** 3.5kg TBC
- **Operating Temperature:** 32°F to 104°F (0°C to 40°C)
- **Storage Temperature :** -4°F to 140°F (-20°C to 60°C)
- **Power Supply:** Internal 110-250V AC

NOTE: Specifications are subject to change without notice. Weights and dimensions are approximate.

## Package Contents

- 1 x DA1414
- 9 x 3 pin 3.5mm pitch Phoenix connector
- 1 x 19" Rack Mounting kit
- 4 x Mounting feet
- 1 x Quick Reference Card
- IEC Power Cable(s)

## Maintenance

Clean this unit with a soft, dry cloth. Never use alcohol, paint thinner or benzene to clean this unit.

# RS-232 Configuration and Telnet Commands

The DA1414 can be controlled via serial and TCP/IP.

The default RS-232 communication settings are:

Baud rate:  
57600 Data bits:  
8 Stop bits: 1  
Parity bit: none

The following pages list all available serial / IP commands.

## Commonly Used Serial Commands

There are several commands that are commonly used for control and testing:

STATUS Status will give feedback on the switcher such as outputs on, type of connection, etc.

PON Power on Power off Toggling the main output

POFF ON or OFF as required

OUTON/OFF

Example: OUTON (This would turn the main output on)

OUT FRyy (yy is the input)

Example: OUT FR04 (This would switch the main output to source input 4)

## Common Mistakes

- Carriage return: Some programs do not require the carriage return where as other will not work unless sent directly after the string. In the case of some Terminal software the token <CR> is used to execute a carriage return. Depending on the program you are using this token maybe different. Some other examples that other control systems deploy include \r or 0D (in hex)
- Spaces: Blustream commands do not require space between commands unless specified. There may be some programs that require spacing in order to work.
  - How the string should look is as follows: OUTON
  - How the string may look if spaces are required: OUT{Space}ON
- Baud rate or other serial protocol settings not correct

RS-232 Configuration and Telnet Commands (continued)

COMMAND	ACTION
?/HELP	Print Help Information
STATUS	Print System Status And Port Status
UPTIME TEMP	Print System Uptime
POW POFF	Print System Temperature
	Power On, System Run On Normal State
	Power Off, System Run On Power Save State
PWLED FOLLOW ON/OFF	ON:Set System Power LED Follow LCD Status OFF:Set System Power LED Not Follow LCD Status, In Power On State,Power LED Always On
RESET	Reset System Settings To Default (Should Type "Yes" To Confirm, "No" To Discard)
RESET ALL	Reset System And Network Settings To Default (Should Type "Yes" To Confirm, "No" To Discard)
REBOOT	Set System Reboot
STANDBY xx	Set System Standby Mode To xx xx=0:Sleep,1:Standby
KEY ON/OFF	Set System KEY Control On Or Off
LCD ON/OFF/15/30/60	Set RS232 Baud Rate To xx bps xx=[1...6]:1:4 8 0 0, 2:9 6 0 0, 3:1920 0,4: 3 8 4 0 0, 5:576 0 0, 6:11 520 0
USB PORT xx	Set USB Port To xx xx=[1,2]:1:USB-B,2:USB-C
IN xx NAME yy	Set Input: xx To Name: yy xx=[1...18]:1-4:Analogue Input CH1-CH4,5-12:Dante Input CH1-CH8,13:USB Input Left,14:USB Input Right,15-18:Input Group 1-4 yy:Max 24 Characters
IN xx CH LOCK ON/OFF	Set Input:xx L/R Channels Lock/Unlock xx=[1...14]:1-4:Analogue Input CH1-CH4,5-12:Dante Input CH1-CH8,13:USB Input Left,14:USB Input Right Note:Only Adjacent Two Inputs Can Be Locked As One L/R Pair Likes Input 1/2 Or 3/4 Or USB Left/Right
IN xx PHT ON/OFF	Set Input:xx Phantom Power On Or Off xx=[0]:All Analogue Input Ports xx=[1...4]:Analogue Input CH1-CH4
IN xx GAIN yy	Set Input:xx Gain To yy xx=[0]:All Input Ports xx=[1...18]:1-4:Analogue Input CH1-CH4,5-12:Dante Input CH1-CH8,13:USB Input Left,14:USB Input Right,15-18:Input Group 1-4 yy=[-30...+30]:Input Gain,Step=1dB
IN xx GAIN+yy	Increase Input:xx Gain xx=[0]:All Input Ports xx=[1...18]:1-4:Analogue Input CH1-CH4,5-12:Dante Input CH1-CH8,13:USB Input Left,14:USB Input Right,15-18:Input Group 1-4 yy=[1...10]:Steps yy Can Be Empty(1 Step)

COMMAND	ACTION
IN xx GAIN-yy	Decrease Input:xx Gain xx=[0]:All Input Ports xx=[1...18]:1-4:Analogue Input CH1-CH4,5-12:Dante Input CH1-CH8,13:USB Input Left,14:USB Input Right,15-18:Input Group 1-4 yy=[1...10]:Steps yy Can Be Empty(1 Step)
IN xx MUTE ON/OFF	Set Input:xx Mute On Or Off xx=[0]:All Input Ports xx=[1...18]:1-4:Analogue Input CH1-CH4,5-12:Dante Input CH1-CH8,13:USB Input Left,14:USB Input Right,15-18:Input Group 1-4
IN xx EQ PRESET yy	Set Input:xx GEQ:yy To Preset:yy xx=[0]:All Input Ports xx=[1...18]:1-4:Analogue Input CH1-CH4,5-12:Dante Input CH1-CH8,13:USB Input Left,14:USB Input Right,15-18:Input Group 1-4 yy=[1...3]:1:Flat,2:Custom1,3:Custom2
IN xx EQ LOCK ON/OFF	Set Input:xx EQ L/R Lock/Unlock xx=[0]:All Inputs xx=[1...14]:1-4:Analogue Input CH1-CH4,5-12:Dante Input CH1-CH8,13:USB Input Left,14:USB Input Right
IN xx EQ yy ON/OFF	Set Input:xx EQ yy On/Off xx=[0]:All Inputs xx=[1...18]:1-4:Analogue Input CH1-CH4,5-12:Dante Input CH1-CH8,13:USB Input Left,14:USB Input Right,15-18:Input Group 1-4 yy=[0...8]:EQ Index 0:All
IN xx EQ vv TYPE ww FRQ yy GAIN zz Q aa	Set Input: xx EQ vv To Type ww With FRQ yy GAIN zz Q aa xx=[0]:All Inputs xx=[1...18]:1-4:Analogue Input CH1-CH4,5-12:Dante Input CH1-CH8,13:USB Input Left,14:USB Input Right,15-18:Input Group 1-4 vv=[0...8]:EQ Index 0:All ww=[1...5]:Filter Type:1:Parametric,2:Lowpass,3:Highpass,4:Low Shelf,5:High Shelf yy=[20...20000]:Frequency Value[Hz] zz=[-15...+15]:Gain Value[dB](Step=0.1) aa=[0.02...50]:Q Value(Step=0.01)
IN xx EQ CLR	Set Input:xx EQ Clear xx=[0]:All Inputs xx=[1...18]:1-4:Analogue Input CH1-CH4,5-12:Dante Input CH1-CH8,13:USB Input Left,14:USB Input Right,15-18:Input Group 1-4

RS-232 Configuration and Telnet Commands (continued)

COMMAND	ACTION	COMMAND	ACTION
IN GROUP zz MEMBER yy	<p>Set Input Group:zz Includes yy</p> <p>zz=01:Input Group 1                      zz=02:Input Group 2                      zz=03:Input Group 3                      zz=04:Input Group 4</p> <p>yy[13]:Analogue CH1 In                      yy[12]:Analogue CH2 In                      yy[11]:Analogue CH3 In                      yy[10]:Analogue CH4 In                      yy[9]:Dante CH1 In yy[8]:Dante CH2 In yy[7]:Dante CH3 In                      yy[6]:Dante CH4 In yy[5]:Dante CH5 In yy[4]:Dante CH6 In                      yy[3]:Dante CH7 In yy[2]:Dante CH8 In yy[1]:USB Left In                      yy[0]:USB Right In                      [bit]=1:Included                      [bit]=0:Excluded</p>	OUT xx VOL-yy	<p>Decrease Output:xx Volume</p> <p>xx=[0]:All Output Ports                      xx=[1...18]:1-4:Analogue Output CH1-CH4,5-12:Dante Output CH1-CH8,13:USB Output Left,14:USB Output Right,15-18:Output Group A-D                      yy=[1...10]:Steps                      yy Can Be Empty(1 Step)</p>
OUT xx NAME yy	<p>Set Output:xx To Name:yy</p> <p>xx=[1...18]:1-4:Analogue Output CH1-CH4,5-12:Dante Output CH1-CH8,13:USB Output Left,14:USB Output Right,15-18:Output Group A-D                      yy:Max 24 Characters</p>	OUT xx MUTE ON/OFF	<p>Set Output:xx Mute On Or Off</p> <p>xx=[0]:All Output Ports                      xx=[1...18]:1-4:Analogue Output CH1-CH4,5-12:Dante Output CH1-CH8,13:USB Output Left,14:USB Output Right,15-18:Output Group A-D</p>
OUT xx CH LOCK ON/OFF	<p>Set Output:xx L/R Channels Lock/Unlock</p> <p>xx=[1...14]:1-4:Analogue Output CH1-CH4,5-12:Dante Output CH1-CH8,13:USB Output Left,14:USB Output Right                      Note:Only Adjacent Two Outputs Can Be Locked As One L/R Pair Likes Output 1/2 Or 3/4 Or USB Left/Right</p>	OUT xx EQ PRESET yy	<p>Set Output:xx PEQ:yy To Preset:yy</p> <p>xx=[0]:All Output Ports                      xx=[1...18]:1-4:Analogue Output CH1-CH4,5-12:Dante Output CH1-CH8,13:USB Output Left,14:USB Output Right,15-18:Output Group A-D                      yy=[1...3]:1:Flat,2:Custom1,3:Custom2</p>
OUT xx FR yy	<p>Set Output:xx From Input:yy</p> <p>xx=[0]:All Output Ports                      xx=[1...14]:1-4:Analogue Output CH1-CH4,5-12:Dante Output CH1-CH8,13:USB Output Left,14:USB Output Right                      yy=[1...14]:1-4:Analogue Input CH1-CH4,5-12:Dante Input CH1-CH8,13:USB Input Left,14:USB Input Right</p>	OUT xx EQ LOCK ON/OFF	<p>Set Output:xx EQ L/R Lock/Unlock</p> <p>xx=[0]:All Outputs                      xx=[1...14]:1-4:Analogue Output CH1-CH4,5-12:Dante Output CH1-CH8,13:USB Output Left,14:USB Output Right</p>
OUT xx VOL yy	<p>Set Output:xx Volume To yy</p> <p>xx=[0]:All Output Ports                      xx=[1...18]:1-4:Analogue Output CH1-CH4,5-12:Dante Output CH1-CH8,13:USB Output Left,14:USB Output Right,15-18:Output Group A-D                      yy=[0...100]:Volume Value</p>	OUT xx EQ yy ON/OFF	<p>Set Output:xx EQ yy On/Off</p> <p>xx=[0]:All Outputs                      xx=[1...18]:1-4:Analogue Output CH1-CH4,5-12:Dante Output CH1-CH8,13:USB Output Left,14:USB Output Right,15-18:Output Group A-D                      yy=[0...8]:EQ Index 0:All</p>
OUT xx VOL+yy	<p>Increase Output:xx Volume</p> <p>xx=[0]:All Output Ports                      xx=[1...18]:1-4:Analogue Output CH1-CH4,5-12:Dante Output CH1-CH8,13:USB Output Left,14:USB Output Right,15-18:Output Group A-D                      yy=[1...10]:Steps                      yy Can Be Empty(1 Step)</p>	OUT xx EQ vv TYPE ww FRQ yy GAIN zz Q aa	<p>Set Output: xx EQ vv To Type ww With FRQ yy GAIN zz Q aa</p> <p>xx=[0]:All Outputs                      xx=[1...18]:1-4:Analogue Output CH1-CH4,5-12:Dante Output CH1-CH8,13:USB Output Left,14:USB Output Right,15-18:Output Group A-D                      vv=[0...8]:EQ Index 0:All                      ww=[1...5]:Filter Type:1:Parametric,2:Lowpass,3:Highpass,4:Low Shelf,5:High Shelf                      yy=[20...20000]:Frequency Value[Hz]                      zz=[-15...+15]:Gain Value[dB](Step=0.1)                      aa=[0.02...50]:Q Value(Step=0.01)</p>
		OUT xx EQ CLR	<p>Set Output:xx EQ Clear</p> <p>xx=[0]:All Outputs                      xx=[1...18]:1-4:Analogue Output CH1-CH4,5-12:Dante Output CH1-CH8,13:USB Output Left,14:USB Output Right,15-18:Output Group A-D</p>
		OUT xx DLYT yy	<p>Set Output:xx Delay Time To yy(ms)</p> <p>xx=[0]:All Output Ports                      xx=[1...14]:1-4:Analogue Output CH1-CH4,5-12:Dante Output CH1-CH8,13:USB Output Left,14:USB Output Right                      yy=[1...50]:Delay Time,Millisecond</p>

**RS-232 Configuration and Telnet Commands (continued)**

COMMAND	ACTION
OUT GROUP zz MEMBER yy	Set Output Group:zz Includes yy zz=01:Output Group A zz=02:Output Group B zz=03:Output Group C zz=04:Output Group D yy[13]:Analogue CH1 Out yy[12]:Analogue CH2 Out yy[11]:Analogue CH3 Out yy[10]:Analogue CH4 Out yy[9]:Dante CH1 Out yy[8]:Dante CH2 Out yy[7]:Dante CH3 Out yy[6]:Dante CH4 Out yy[5]:Dante CH5 Out yy[4]:Dante CH6 Out yy[3]:Dante CH7 Out yy[2]:Dante CH8 Out yy[1]:USB Left Out yy[0]:USB Right Out [bit]=1:Included [bit]=0:Excluded
PRESET xx STATUS	Print Preset Config Status xx=[1...8]:Select Preset Index
PRESET xx SAVE	Save Current Config To Preset:xx xx=[1...8]:Select Preset Index
PRESET xx APPLY	Recall Preset:xx Config To The Current Setting xx=[1...8]:Select Preset Index
PRESET xx DELETE	Delete Preset:xx From The System xx=[1...8]:Select Preset Index
PRESET xx NAME yy	Set Preset:xx To Name:yy xx=[1...8]:Select Preset Index yy:Max 24 Characters
NET DHCP ON/OFF	Set Auto IP(DHCP) On Or Off
NET IP xxx.xxx.xxx.xxx	Set IP Address
NET GW xxx.xxx.xxx.xxx	Set Gateway Address
NET SM xxx.xxx.xxx.xxx	Set Subnet Mask Address
NET TCPPORT ON/OFF	Set TCP/IP On Or Off
NET TCPPORT xxxx	Set TCP/IP Port
NET TN ON/OFF	Set Telnet On Or Off
NET TN xxxx	Set Telnet Port
NET RB	Network Reboot And Apply New Config!!!
NET DNS xxxx	Set DNS Domain Name To xxxx

## Certifications

FCC Notice This equipment has been tested and found to comply with the limits for a Class B digital device, pursuant to part 15 of

the FCC Rules. These limits are designed to provide reasonable protection against harmful interference in a residential

installation. This equipment generates, uses, and can radiate radio frequency energy and, if not installed and used in accordance with the instructions, may cause harmful interference to radio communications. However, there is no guarantee that interference will not occur in a particular installation. If this equipment does cause harmful interference

to radio or television reception, which can be determined by turning the equipment off and on, the user is encouraged to reorient or relocate the receiving antenna.

to increase the separation between the equipment and the receiver.

- Connect the equipment into an outlet on a circuit different from that to which the receiver is connected.
- Consult the dealer or an experienced radio/TV technician for help.

CAUTION - changes or modifications not expressly approved by the party responsible for compliance could void the user's authority to operate the equipment.

### CANADA, INDUSTRY CANADA (IC) NOTICES

This Class B digital apparatus complies with Canadian ICES-003.

Operation is subject to the following two conditions: (1) this device may not cause interference, and (2) this device must accept any interference, including interference that may cause undesired operation of the device.

### CANADA, AVIS D'INDUSTRY CANADA (IC)

Cet appareil numérique de classe B est conforme aux normes canadiennes ICES-003.

Son fonctionnement est soumis aux deux conditions suivantes : (1) cet appareil ne doit pas causer d'interférence et (2) cet appareil doit accepter toute interférence, notamment les interférences qui peuvent affecter son fonctionnement.

### CORRECT DISPOSAL OF THIS PRODUCT

This marking indicates that this product should not be disposed with other household wastes. To prevent possible harm to the environment or human health from uncontrolled waste disposal, recycle it responsibly to promote the sustainable reuse of material resources. To return your used device, please use the return and collection systems or contact the retailer where the product was purchased. They can take this product for environmentally safe recycling.



**BLUSTREAM** 

