

Lapbank TL 32- 6760

WARNING



- Children must be under surveillance to ensure that they do not play with this piece of electrical equipment.
- The product is shipped fully assembled, if the unit is being stored do not double stack.
- Ensure that all casters are released from their brakes and are running freely when being moved.
- This unit is not designed for rough terrain.
- Please treat sympathetically avoiding kerbs or changes in level and being especially careful when changing floor surfaces or crossing sloping areas. Take your time. If in doubt ask a second person to assist you.
- Ensure the outlet socket the trolley is connected to is easily accessible
- The weight of the trolley exceeds 25kg, Do not attempt to lift the trolley.

Maintenance Instructions

- There are no user maintenance or adjustment points on this machine. Simply clean dust and dirt from the outside of the unit and inspect for damage or breaks.
- Cleaners and disinfectants must not be highly alkaline or acidic.
- The user should visually check the equipment for signs of wear or misuse before each time of using and for the security of the screen or any accessories.
- The condition of electrical cables and plugs should be checked for wear or abrasion before use.
- In addition, the equipment should be visually inspected in more detail every three months to ensure that the unit is functioning properly and if it is not the user should report this to the manufacturer for advice or for the return of the unit to base for repair.
- Incidences of misuse must be reported immediately and the unit placed out of commission.
- All repairs to the unit must only be carried out by Loxit.
- The warranty is only valid in so far as the equipment has been used and maintained correctly and has not been tampered with.
- Violent treatment will invalidate the warranty.
- During operation if the unit makes any unusual noises or smells turn off the power supply at the mains immediately.
- Ambient temperature range +5deg C to +40 deg C.

Safety

Before Charging Please Check:

1. The wall socket is switched on
2. The RESET button on the RCD is pushed in
3. The red neon indicator switch on the power strip is switched on and lit if applicable, or the rocker switch in the case of ChargeConnect products.

4. The IEC lead is plugged into the IEC inlet and the IEC Inlet switch is turned on with the neon indicator light illuminated.
5. The low voltage power leads are firmly connected to the power source (device transformer or ChargeConnect) and the device.

Lapbank TL products must be connected to an RCD protected earthed mains supply when charging.

Power Rating:

230v – 50 Hz – 10 amps. **TOTAL NOT TO EXCEED 10 amps.** OUTPUT – 230V AC – 10 amps.

Fuses located within the plug and Power inlet IEC block are the only user serviceable parts within the unit, any warranty and service issues should be referred to your supplier.

Power input IEC block fuse: Fast Blow Glass Fuse, 10A, 250V (F10AL250V)

Mains cable plug fuse: 10A BS1362 Fuse

In the event of the mains plug or lead being damaged, the unit should not be used until a new plug or lead has been fitted by a competent person. The old plug or lead must be safely disposed of.

THE MAINS INPUT TO THE LAPBANK TL TROLLEY MUST ONLY BE PLUGGED INTO AND REMOVED FROM A SWITCHED MAINS PLUG SOCKET WHICH IS TURNED OFF.

Please ensure the mains input cable is unplugged before unlocking the wheels (if applicable) and moving the trolley.

DO NOT DROP THE RCD PLUG, it contains sensitive electronics and may become damaged.

Mains input cables must be inspected daily for damage and wear.

If any fault or damage is found with any mains input cable, remove all power sources and stop using immediately. Contact Loxit Limited on +44 (0) 845 519 5191 for a replacement cable.

Visit www.loxit.com for contact details or sales@loxit.com to e-mail.

UNDER NO CIRCUMSTANCES SHOULD REPAIRS BE MADE TO THE MAINS INPUT CABLE.

- This Laptop storage and charging product must only be used by a competent adult and must not be used if this can not be assured.
- If you are in any doubt please refer to your Health and Safety Co-ordinator and/or Health and Safety Manual for guidance.
- This product requires PAT testing at maximum 12 monthly intervals.
- Portable Appliance Testing- This unit must only be earth bond and insulation tested using the IT settings on any PAT tester.
- WEEE Directive- When the unit becomes redundant it must be disposed of in compliance with the WEEE directive 2005.



Cabling instructions

1. **A.** Unfasten the charge compartment hatch by removing the three M5 bolts indicated.

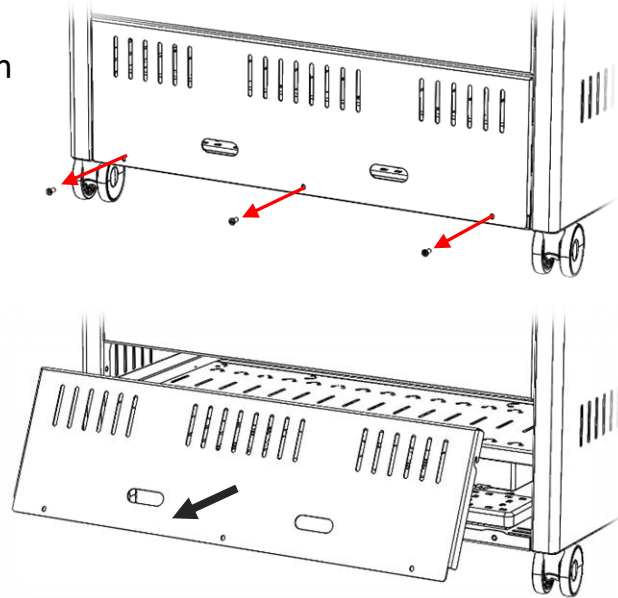

- B.** Lift the hatch upwards and unhook it from the Lapbank TL.
Repeat this for both sides.

2. Remove the cover panels on both sides of the trolley.

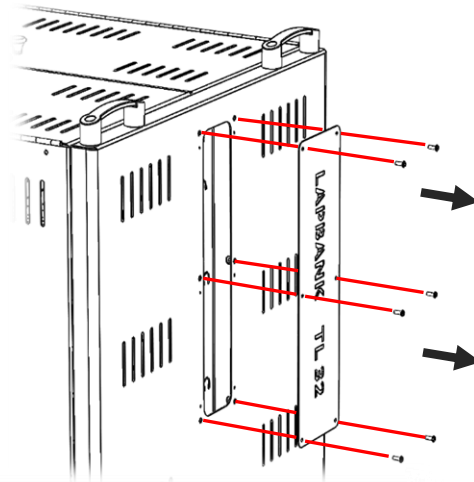

3. Unlock and open the laptop compartment doors. Remove the eight M5 bolts indicated then lift off the cover.

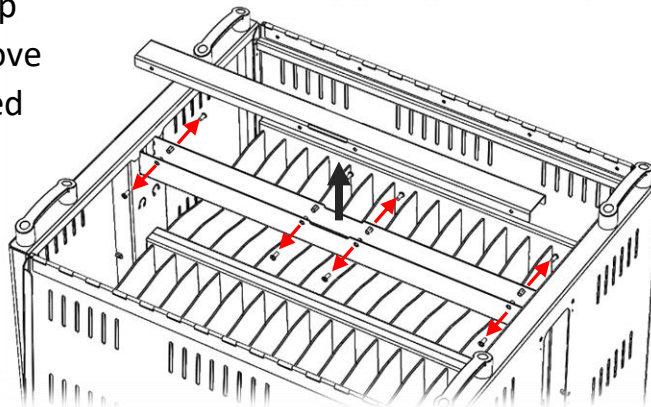

4. Remove the transformer trays by unscrewing the two M4 thumb screws (one at each side) and then lifting the tray out. Do this for both transformer trays.

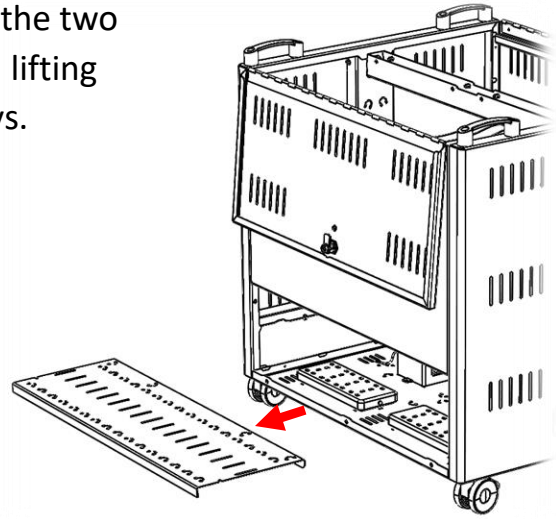

5. Plug the transformer mains leads into the sockets, if possible unplug the mains lead from the transformer.

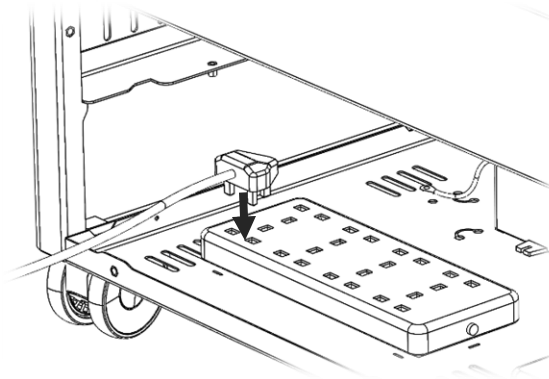

6. **A.** Load 8 of the transformers onto the left side of the tray and secure them in place using cable ties or velcro straps

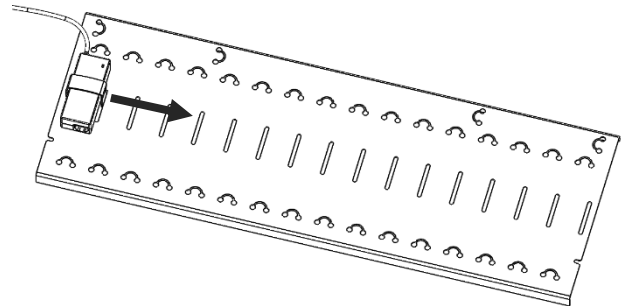

- B.** Route the charging cables to the left and cable tie them in place.

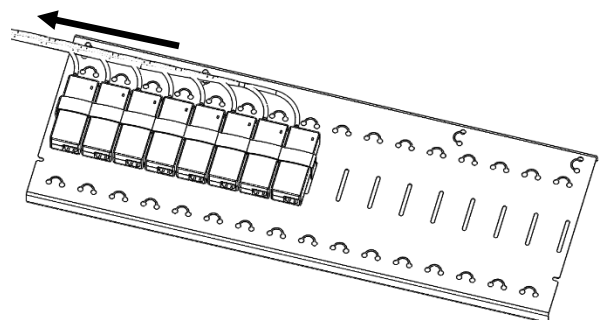

C. Load a further 8 transformers onto the right side of the tray and secure them in place using cable ties or velcro straps. Route the charging cables to the right and cable tie them in place.

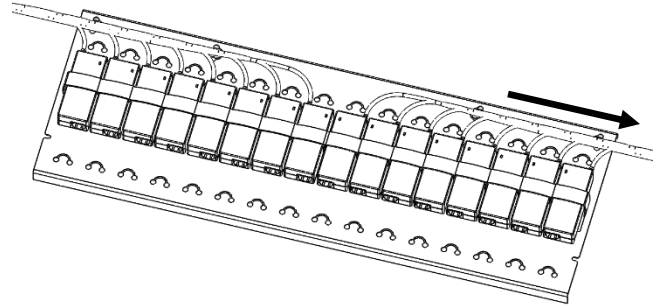

7. Locate the loaded transformer tray back into the charge compartment and secure using the M4 thumb Screws removed during step 4.
8. Plug the mains leads back into the transformers and secure any loose excess cable using cable ties.
9. Repeat steps 4-8 for the other side.
10. Feed the charging cables up through the channels at each side of the unit and into the central tray, there should be 16 cables per side.

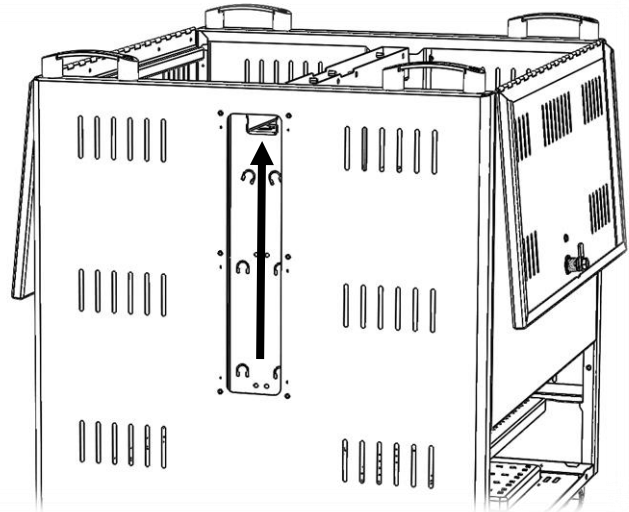

11. Pass the cables through the grommets in the central tray, make sure there is enough slack to reach your device. It is recommended to drop the shortest cables through the nearest grommet where possible.

Once all the cables are in place cable tie them in place in the channels at either side.

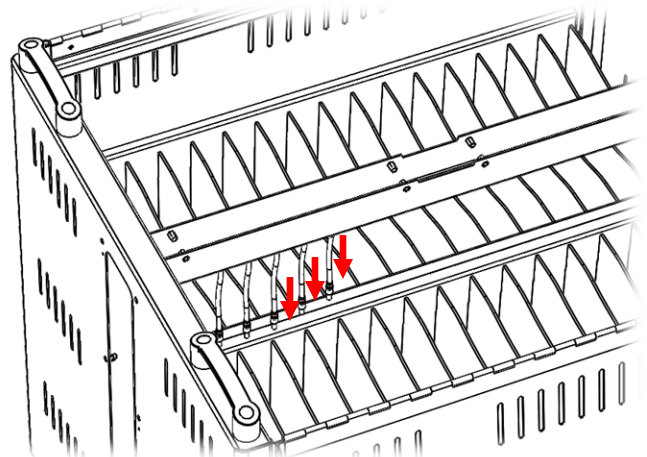

12. Replace the central cover and fix in place using the eight M5 fixings removed in step 3.

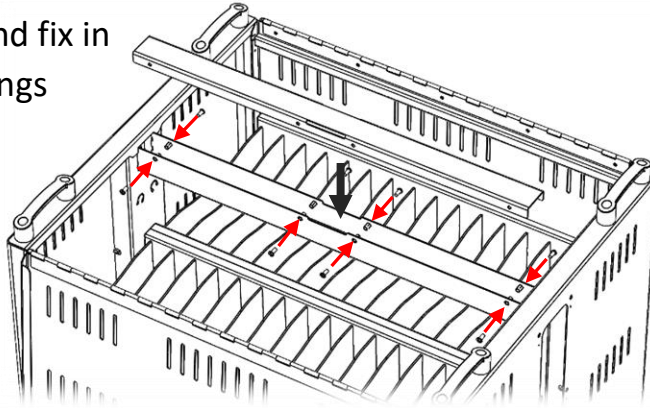

13. Replace both the side covers and fix in place using the six M5 fixings removed in step 4.

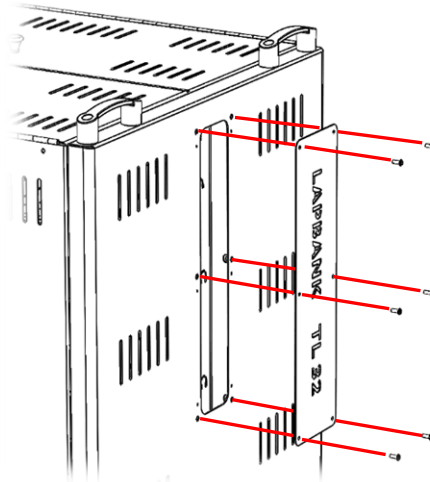

14. **A.** Hook the charging compartment hatches back into place

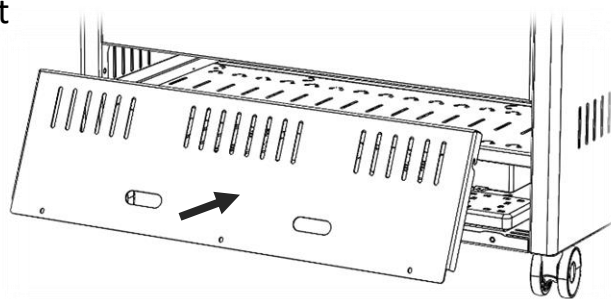

B. Secure the hatch using the three M5 fixings removed in step 1.

