

Heavy Duty Mono 500/600 – Wall mount 8410 and 8411

-Maximum Weight Capacity 170kg -Screen Sizes 75 to 105in



WARNING

Safety instructions

Do not attempt to install or use this product until all the instructions and warnings have been read and understood. Please retain these instructions for future reference.

Failure to follow these instructions may result in accident leading to serious injury or death.

Failure to follow these instructions may result in the product being damaged or destroyed and the warranty voided.

Loxit Products Ltd is not responsible for injury or damage caused by improper installation, improper usage or failure to follow these instructions.

- Never exceed the maximum weight and/or screen size indicated. The use of equipment exceeding the maximum weight and/or screen size may cause instability and/or product failure.
- Ensure the areas above and below any moving parts of the product are kept clear of obstructions at all times.
- It is the responsibility of the installer to ensure that the wall and the fixings used are capable of safely bearing the load of the product and any equipment installed on it.
- The product must only be used on a floor which is hard, flat and level.
- The base of the product must be in full contact with the floor to prevent stability issues.
- The floor surface the product is installed upon must be capable of safely bearing the weight of the product and any equipment installed on the product.
- Hitting, pushing/pulling or climbing on the product may result in damage and/or failure of the product and may cause the weakening and/or failure of the fixings used to secure the product to the wall and/or floor.
- Children must not be allowed to operate the product or have access to the controls.
- To prevent bodily injury, keep hands and clothing away from moving parts when the product is in operation.
- Before installing the product or working with its connections, unplug the product from the mains power supply socket.
- The product must only be used indoors in a dry area and it must be ensured before use that the product is safe or protected from liquid contact or spillage.
- Unplug the product IMMEDIATELY in the following conditions:
 - When the power cord or plug is damaged or frayed.
 - If liquid has spilled into the product.
 - If the product has been exposed to rain or water.
 - If the product exhibits a distinct change in performance, indicating a need for servicing.
- Do not place the product in places subject to extreme temperatures, for example near a radiator, or heating vent.

1. Fix the brackets to the wall where the heavy-duty lift is to be mounted. Dimension A shown in the diagram is the distance to the top of the upper mount bracket. The bracket should sit just below the collar of the lifting column. Check that the floor where the lift is to be situated is flat.

Dimension A

(Distance to top of highest mount bracket)

Mono 500 A = 620mm

Mono 600 A = 880mm

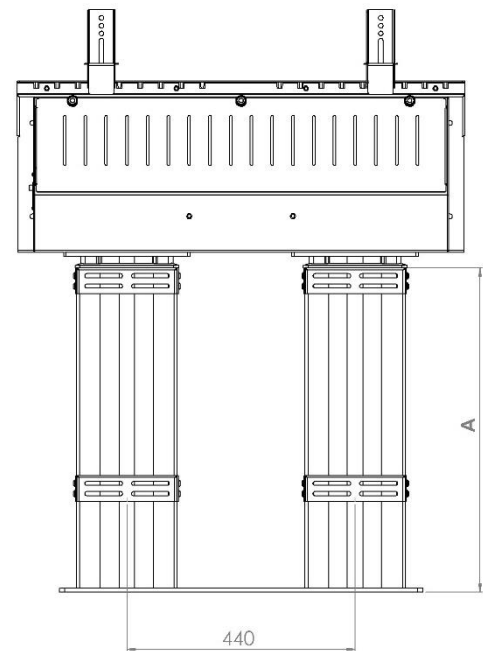

2. With the four brackets fixed to the wall move the heavy duty lift up to the brackets and check the alignment of the brackets with the columns. If the columns align with the brackets use the U-Shaped straps to secure the lift to the wall as shown in the diagram. Each strap should be secured with four M8 bolts.

Upper bracket should be mounted just below the collar of the column.

Lower bracket should be mounted down near the base of the column.

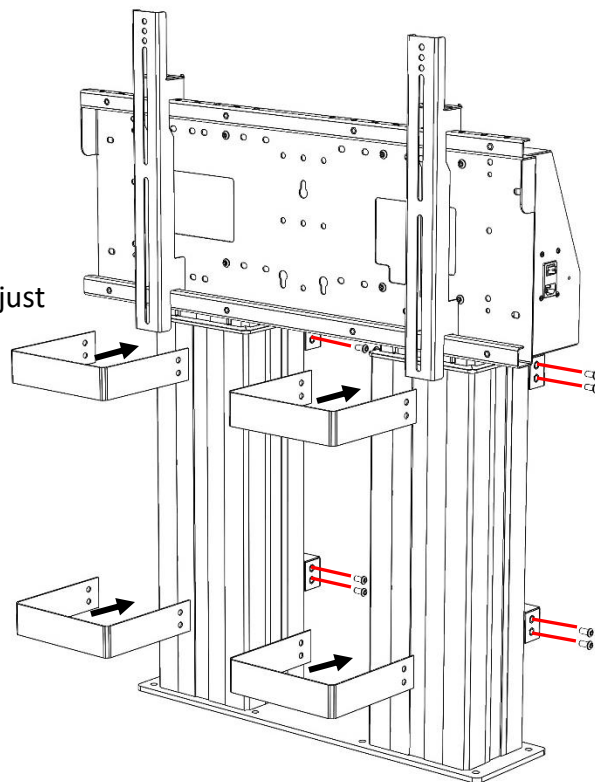

3. Attach the brackets to the back of the screen using the appropriate fixings, make sure the brackets are as central as possible.

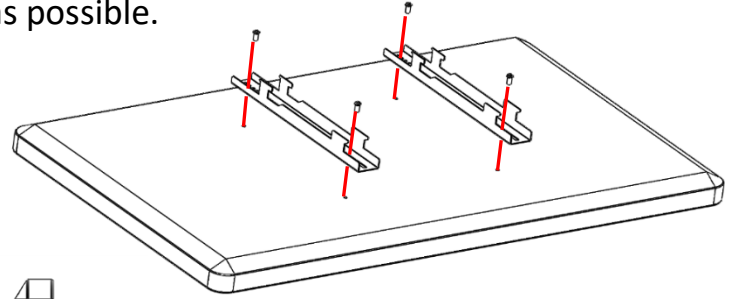

4. Hook the screen onto the mount plate.

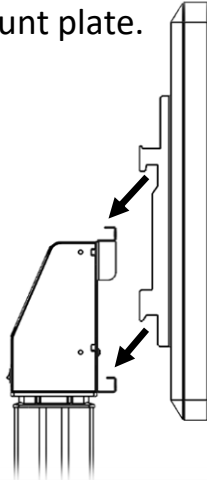

5. Secure the screen in place using the clips and two M6*50mm bolts with washers.

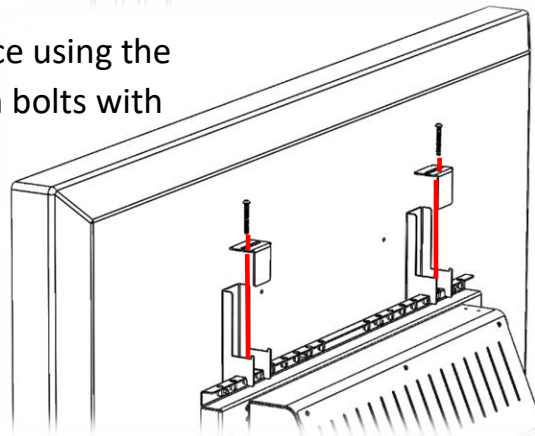

6. To access the integrated 4-way power strip in the headbox, unscrew the three fixings indicated and lift off the vanity cover.

