

Heavy Duty Mono 500/600 - Freestanding 8405 and 8406

-Maximum Weight Capacity 170kg -Screen Sizes 75 to 105in



WARNING

Safety instructions

Do not attempt to install or use this product until all the instructions and warnings have been read and understood. Please retain these instructions for future reference.

Failure to follow these instructions may result in accident leading to serious injury or death.

Failure to follow these instructions may result in the product being damaged or destroyed and the warranty voided.

Loxit Products Ltd is not responsible for injury or damage caused by improper installation, improper usage or failure to follow the instructions.

- Never exceed the maximum weight and/or screen size indicated. The use of equipment exceeding the maximum weight and/or screen size may cause instability and/or product failure.
- Ensure the areas above and below any moving parts of the product are kept clear of obstructions at all times.
- The product must only be used on a floor which is hard, flat and level to prevent stability issues.
- The floor the product is used upon must be capable of safely bearing the weight of the product and any equipment installed on the product.
- The product is not fixed to the ground and may tip or fall over if the product is hit, pushed/pulled or climbed upon.
- Children must not be allowed to operate the product or have access to the controls.
- To prevent bodily injury, keep hands and clothing away from moving parts when the product is in operation.
- Before installing the product or working with its connections, unplug the product from the mains power supply socket.
- The product must only be used indoors in a dry area and it must be ensured before use that the product is safe from liquid contact or spillage.
- Unplug the product IMMEDIATELY in the following conditions:
 - When the power cord or plug is damaged or frayed.
 - If liquid has spilled into the product.
 - If the product has been exposed to rain or water.
 - If the product exhibits a distinct change in performance, indicating a need for servicing.
- Do not place the product in places subject to extreme temperatures, for example near a radiator or heating vent.

Assembling the base

1. The lift columns should be bolted to the base using four of the M10 bolts and nyloc nuts provided per column, these should then be covered with the caps provided.

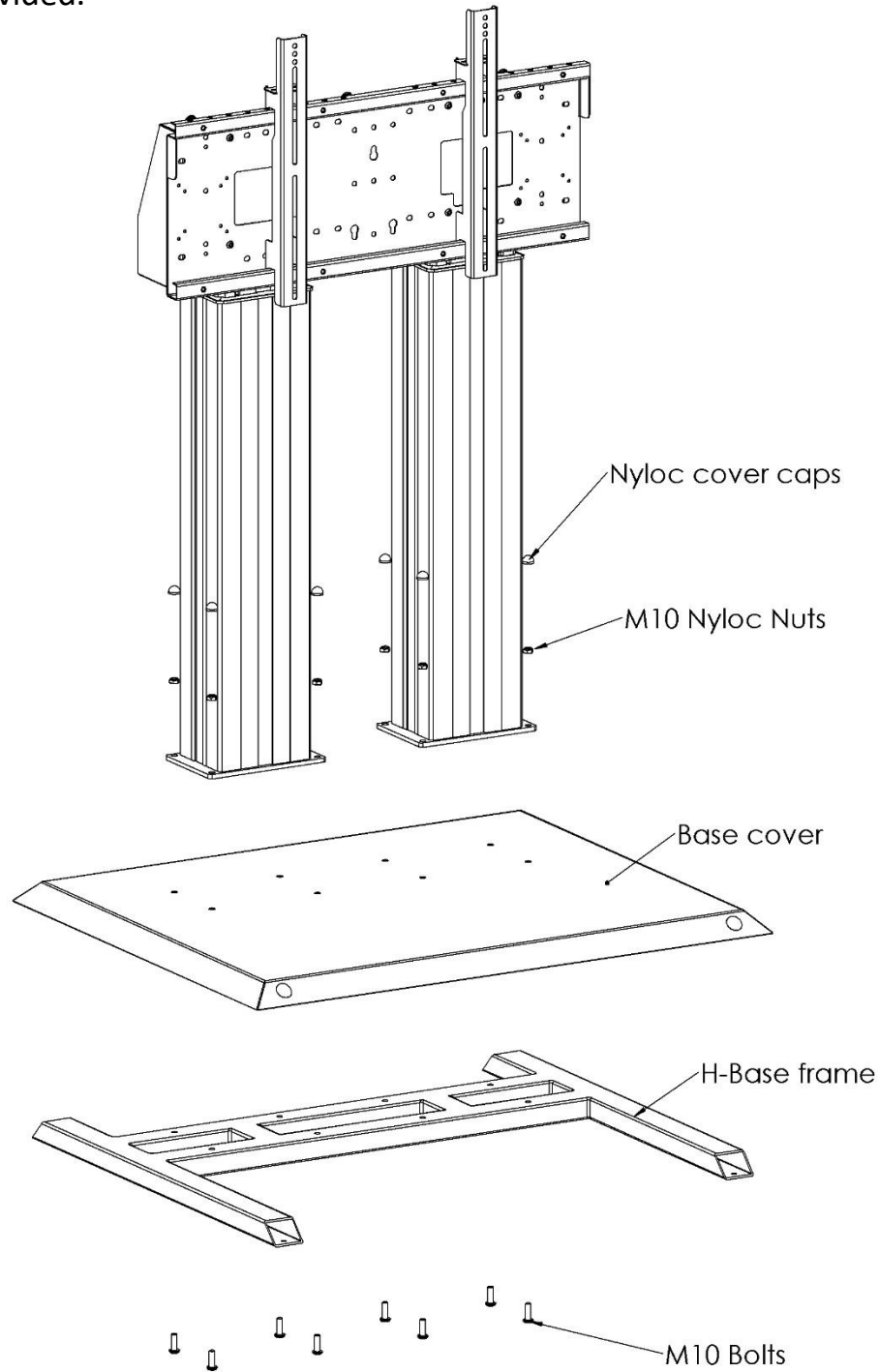

Fixing to the floor (Optional)

The base of the unit can be bolted to the floor for extra security and stability, although this is optional.

1. To access the fixing holes, first remove the four cover caps.

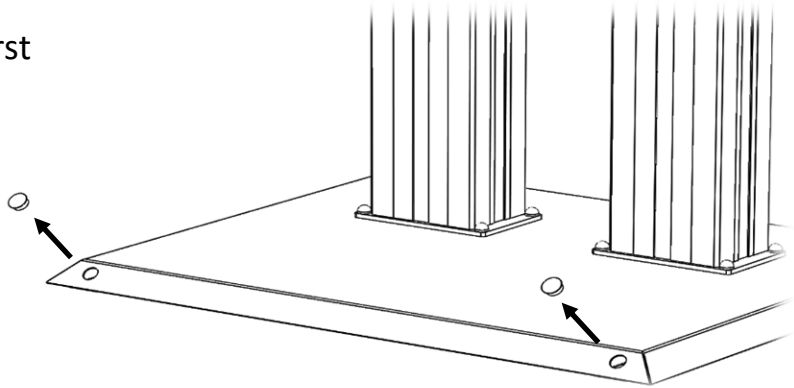

2. The base can now be fixed to the floor using fixings up to 8mm in size.

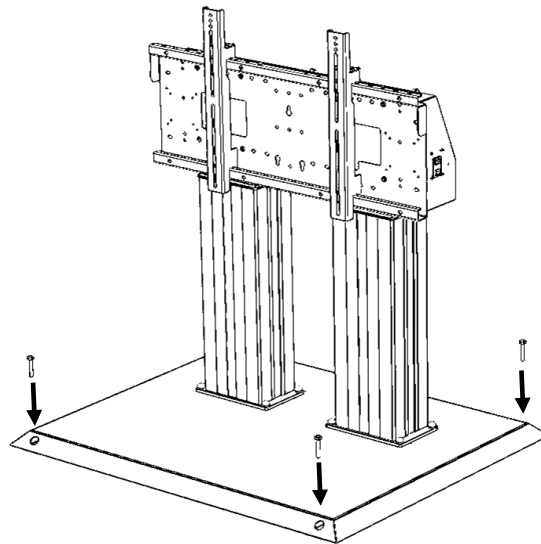

3. With the fixings in place the cover caps can now be pressed into place to conceal the fixing holes.

Mounting the Screen

1. Attach the brackets to the back of the screen using the appropriate fixings, make sure the brackets are as central as possible.

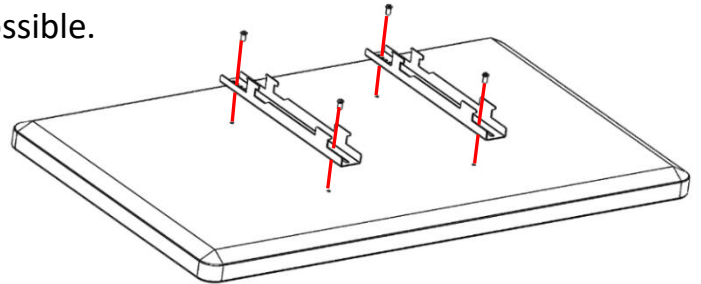

2. Hook the screen onto the mount plate.

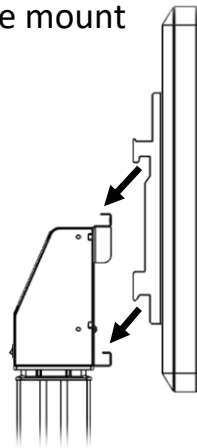

3. Secure the screen in place using the clips and two M6*50mm bolts with washers.

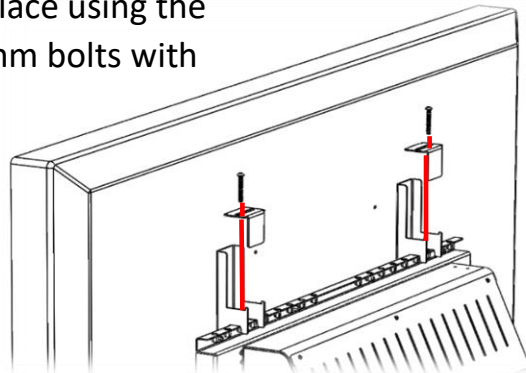

4. To access the integrated 4-way power strip in the headbox, unscrew the three fixings indicated and lift off the vanity cover.

